



Interoffice Memorandum

RCUD
MAY18'20PM4:34

May 18, 2020

To: Katie Smith, Manager
Comptroller Clerk's Office

Through: Cheryl Gillespie, Agenda Development Supervisor
Agenda Development

From: David D. Jones, P.E., CEP, Manager 
Environmental Protection Division
(407) 836-1406

Staff Person: **Elizabeth R. Johnson, CEP, Assistant Manager**
Environmental Protection Division
(407) 836-1511

Subject: Request for Public Hearing on June 23, 2020, at 2:00 p.m., for a Shoreline Alteration/Dredge and Fill Permit Application (SADF-20-04-009) for a new seawall along a portion of the shoreline of the Fischer Canal located at 11 Main Street, Windermere, FL 34786, Parcel ID No. 08-23-28-1948-01-080, District 1

Applicant: Ashley Walker

Type of Hearing: Shoreline Alteration/Dredge and Fill Permit Application

Hearing required by Florida Statute # or Code: Chapter 33, Article IV, Windermere Water and Navigation Control District

Advertising requirements: Publish once in a newspaper of general circulation in Orange County at least (7) seven days prior to public hearing.

Advertising timeframes: At least (7) seven days prior to public hearing.

Abutters to be notified: The applicant and the property owners within 500 feet of the project area will be notified at least (7) seven days prior to public hearing by the Environmental Protection Division (EPD).

Lake Advisory Board to be notified: Windermere Water and Navigation Control District,
Ijaz Ahmed (Chairman) – ijazahmed736@gmail.com

LEGISLATIVE FILE # 20-726

June 23, 2020
@
2pm

May 18, 2020

Request for Public Hearing—Shoreline Alteration/Dredge and Fill Permit Application for Ashley Walker (SADF-20-04-009)

Page Two

Estimated time required
For public hearing: 2 minutes

Municipality or other
Public Agency to be
notified: Florida Department of Environmental Protection—
DEP_CD@dep.state.fl.us

Hearing Controversial: No

District #: 1

Materials being submitted as backup for public hearing request:

1. Site Plan
2. Location Map

Special Instructions to Clerk:

1. Once the Board of County Commissioners makes a decision on the Shoreline Alteration/Dredge and Fill Permit Application, please submit the decision letter to Michelle Gonzalez with EPD. EPD will issue the decision to the applicant.

Advertising Language:

1. Applicant, Ashley Walker, is requesting a Shoreline Alteration/Dredge and Fill Permit (SADF-20-04-009) in order to construct a new seawall along a portion of the shoreline of the Fischer Canal located at 11 Main Street, Windermere, FL 34786, Parcel ID No. 08-23-28-1948-01-080. District 1 (property legal description on file at EPD).

Attachments

ER/NT/TH/EJ/DDJ: mg

Shoreline Alteration/Dredge and Fill Permit Request



**Shoreline Alteration/Dredge
and Fill Permit Request**
SADF-20-04-009
District #1

Applicant: Ashley Walker
Address: 11 Main Street
Parcel ID: 08-23-28-1948-01-080

Project Site 
Property Location 

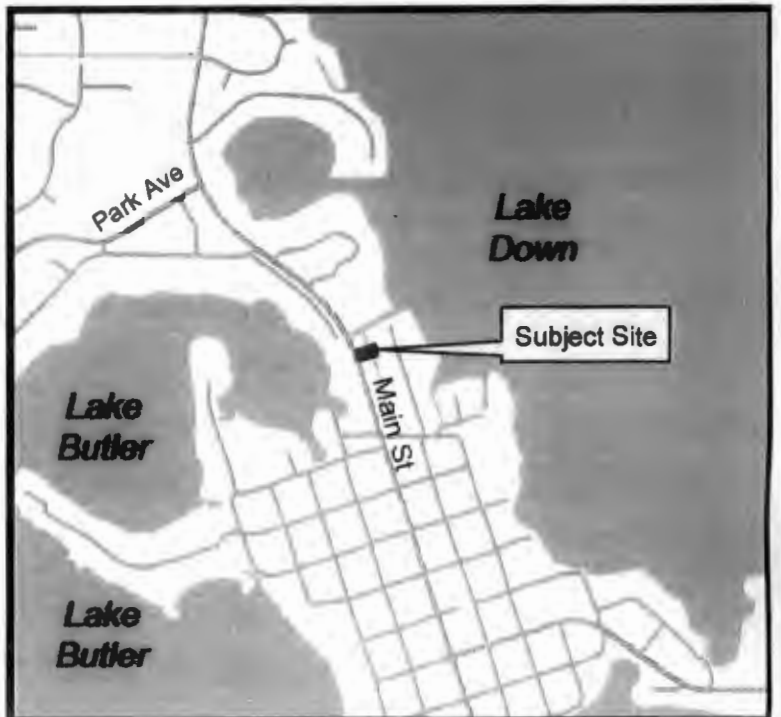

ENGINEERING MEETS OR EXCEEDS 2017 FLORIDA BUILDING CODE, 6th EDITION, CH. 16.

SOIL PROPERTIES:
 $\phi = 35^\circ$
 $\rho = 110 \text{ pcf}$
 $C = 0$

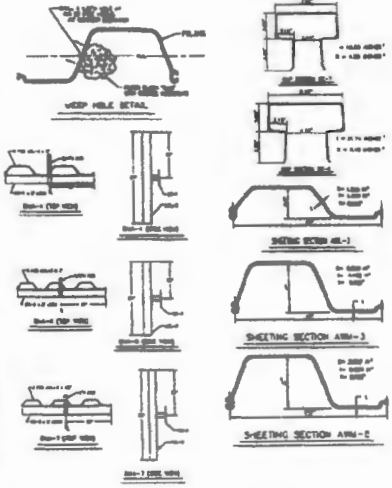
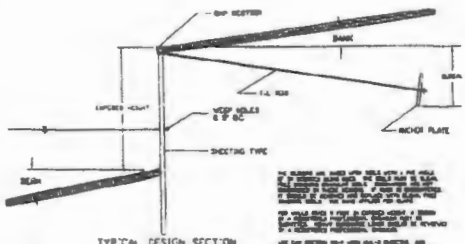

EXPOSED HEIGHT	BANK ANGLE	BENCH ANGLE	SHEETING TYPE	SHEET LENGTH	ANCHOR ROD DIA. & LENGTH	ANCHOR PLATE TYPE & BURIAL	ANCHOR SPACING
3'	0	0	AWL-3	5'	3/4" x 12'	AWL-4 3.3'	8.333'
	10	15	AWL-3	6'	3/4" x 12'	AWL-4 3.3'	8.333'
4'	0	0	AWL-3	6'	3/4" x 12'	AWL-4 4.2'	8.333'
	10	15	AWL-3	7'	3/4" x 12'	AWL-4 4.2'	8.333'
5'	0	0	AWL-3	7'	3/4" x 12'	AWL-4 5.2'	8.333'
	10	15	AWL-3	8'	3/4" x 12'	AWL-4 5.2'	8.333'
6'	0	0	AWL-3	8'	3/4" x 12'	AWL-4 6.2'	8.333'
	10	15	AWL-3	9'	3/4" x 12'	AWL-4 6.2'	8.333'
7'	0	0	AWL-3	9'	3/4" x 12'	AWL-4 7.2'	8.333'
	10	15	AWL-3	10'	3/4" x 12'	AWL-4 7.2'	8.333'
8'	0	0	AWL-3	10'	3/4" x 12'	AWL-4 8.2'	8.333'
	10	15	AWL-3	11'	3/4" x 12'	AWL-4 8.2'	8.333'
9'	0	0	AWL-3	11'	3/4" x 12'	AWL-4 9.2'	8.333'
	10	15	AWL-3	12'	3/4" x 12'	AWL-4 9.2'	8.333'

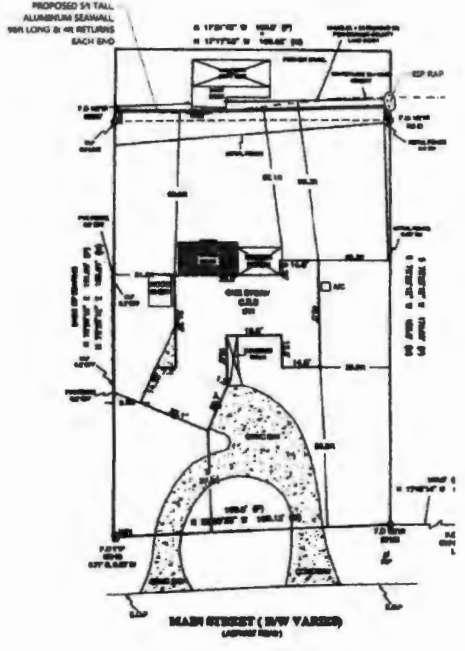
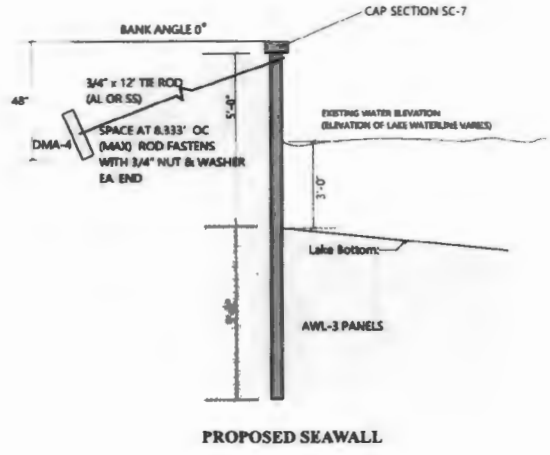

SITE PLAN
 1" = 20'-0"

SEAWALL FOR:
 ASHLEY WALKER
 11 MAIN ST.
 WINDERMERE, FL 34786

PAGE 1 OF 1

Lidon Engineering Company, Inc
 920 Sunset Shores Dr
 Miramar, Florida 34715
 (352) 384-2580 Ph & FAX
 Cert Auth 82888

Wayne Block
 Digitally signed by Wayne Block
 DN: c=US, st=Florida, ou=Lidon Engineering Company, Inc, email=wayne@lidon.com, cn=Wayne Block
 Date: 2020.05.07 09:00:00 -0500

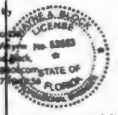

May 7, 2020
 Wayne A. Block, PE#52563