



Interoffice Memorandum

October 2, 2023

TO: Mayor Jerry L. Demings  
-AND-  
County Commissioners

FROM: Andres Salcedo, P.E., Acting Director  
Planning, Environmental, and Development  
Services Department *Andrés*

CONTACT PERSON: Renée H. Parker, LEP, Manager *RHP*  
Environmental Protection Division  
(407) 836-1420

SUBJECT: November 28, 2023 – Consent Item  
State of Florida Department of Environmental Protection Grant  
Agreement No. NS104 for Shingle Creek Stormwater Pond #6459  
Improvement Construction

The Lake Okeechobee Basin Management Action Plan (BMAP) requires the reduction of Total Phosphorus nutrient loads. Shingle Creek Pond #6459 is an existing stormwater treatment pond located at 5656 Starbright Drive within the BMAP area. Contractors for the Orange County Environmental Protection Division are designing improvements to the existing stormwater pond that will enhance nutrient removal. The improvements include increasing residence time within the pond, constructing a sidebank filter consisting of biosorption activated media, and constructing a pump station to treat additional water from the adjacent Americana Outfall Canal.

The Florida Department of Environmental Protection is providing funding assistance to Orange County in the form of a Statewide Water Quality Assistance Grant (SWAG). The SWAG agreement will reimburse Orange County \$500,000 of the estimated \$1,691,231 cost to construct the improvements. The SWAG funding will assist Orange County's water quality improvement efforts by reducing pollutant loads in the basin served by Pond #6459 by an estimated 639 lbs. of Total Nitrogen and 84 lbs. of Total Phosphorus, annually.

This Agreement was reviewed by the County Attorney's Office and approved as to form.

**ACTION REQUESTED: Approval and execution of State of Florida Department of Environmental Protection Standard Grant Agreement Shingle Creek Pond 6459: BMP Treatment Train Agreement Number: NS104 between State of Florida Department of Environmental Protection and Orange County. District 6.**

AS/ERJ:js  
Attachment

# ATTACHMENT 1: SITE VICINITY MAP, STORMWATER POND #6459

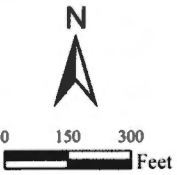

- Legend**
- Basin
  - Winter Run Outfall Canal
  - Pipe
  - Control Structure
  - Curb Inlet
  - Mitered End Treatment

Sources  
 Aerial: Orange County, 2019  
 Structures: Orange County, 2019  
 Parcel: Orange County, 2019  
 Road: Orange County, 2017

Figure  
4-1

**Improvement Site 3:  
Pond #6459  
Site Map**

Shingle Creek Watershed  
BMP Evaluation



# ATTACHMENT 2: SIDEBANK FILTER AND PLANTINGS

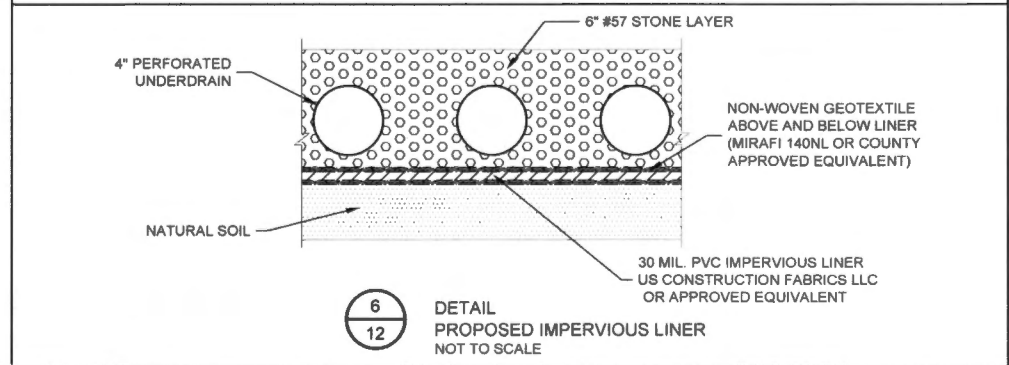
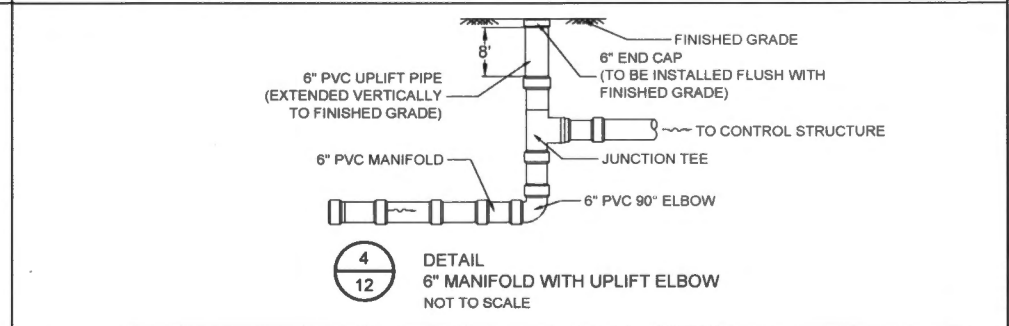
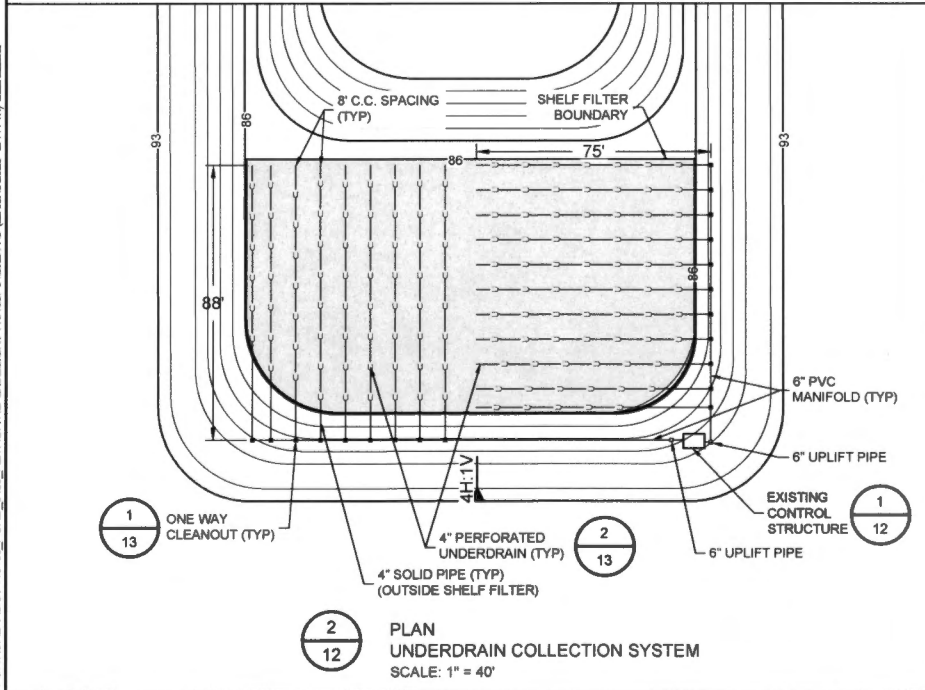
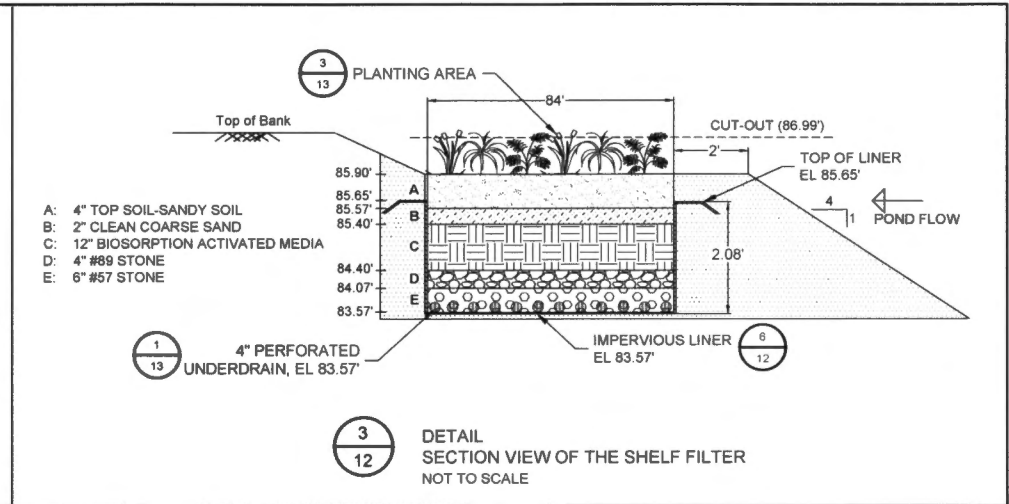
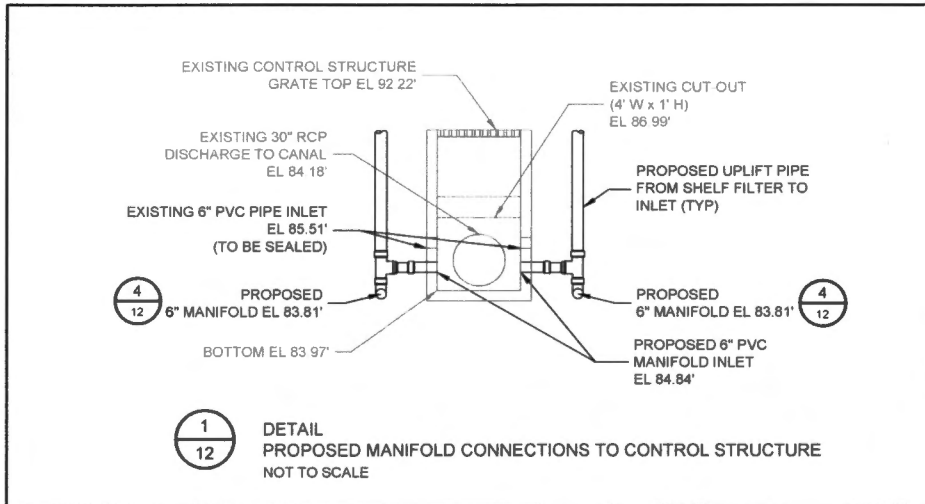

INGEO OFFICE SUPPORTOR (AND/OR) RM: 05\_POND\_6459 RETROFIT (CAD) DESIGN (M: 13) PLOT (2) June 2023 - 2:41 PM (M) B.Landwehr

REVISIONS	
DATE	DESCRIPTION

**POND #6459  
WATER QUALITY RETROFIT**



**Geosyntec**  
consultants  
3504 LAKE LYNEEA DRIVE  
SUITE 105  
ORLANDO, FL 32811  
Mike Harbin, PE  
FL PE# 74749  
AUTHORIZATION NUMBER 4321

**DRAINAGE & MISCELLANEOUS  
DETAILS (1)**

SHEET  
NO  
**12**

BCC Mtg. Date: November 28, 2023

**STATE OF FLORIDA  
 DEPARTMENT OF ENVIRONMENTAL PROTECTION  
 Standard Grant Agreement**

**This Agreement is entered into between the Parties named below, pursuant to Section 215.971, Florida Statutes:**

1. Project Title (Project): **Shingle Creek Pond 6459: BMP Treatment Train** Agreement Number: **NS104**

2. Parties **State of Florida Department of Environmental Protection,  
 3900 Commonwealth Boulevard  
 Tallahassee, Florida 32399-3000** (Department)

Grantee Name: **Orange County** Entity Type: **Local Government**

Grantee Address: **201 S. Rosalind Ave., Orlando, Florida 32801** FEID: **59-6000773**  
 (Grantee)

3. Agreement Begin Date: **Upon Execution** Date of Expiration: **03/31/2027**

4. Project Number: \_\_\_\_\_ Project Location(s): **Lat/Long (28.48086, -81.42528)**  
 (If different from Agreement Number)

Project Description: **The Grantee will construct a stormwater treatment train through expansion of an existing pond, installation of a pump station, and construction of a side bank filtration system with bioactive media at the outfall.**

5. Total Amount of Funding:	Funding Source?	Award #s or Line Item Appropriations:	Amount per Source(s):
<b>\$ 500,000.00</b>	<input checked="" type="checkbox"/> State <input type="checkbox"/> Federal	<b>SWAG, GAA LI 1666, FY 22-23, LATF</b>	<b>\$ 500,000.00</b>
	<input type="checkbox"/> State <input type="checkbox"/> Federal		\$
	<input type="checkbox"/> Grantee Match		\$
<b>Total Amount of Funding + Grantee Match, if any:</b>			<b>\$ 500,000.00</b>

6. Department's Grant Manager	Grantee's Grant Manager
Name: <b>Kate Pace</b>	Name: <b>Emily Lawson, P.E.</b>
or successor	or successor
Address: <b>Florida Dept. of Environmental Protection          3900 Commonwealth Blvd., MS 3570          Tallahassee, FL 32399-3000</b>	Address: <b>Orange County          3165 McCrory Place, Suite 200          Orlando, FL 32803</b>
Phone: <b>850-245-2864</b>	Phone: <b>321-689-7576</b>
Email: <b>Katelyn.Pace@FloridaDEP.gov</b>	Email: <b>Emily.Lawson@ocfl.net</b>

7. The Parties agree to comply with the terms and conditions of the following attachments and exhibits which are hereby incorporated by reference:

<input checked="" type="checkbox"/> Attachment 1: Standard Terms and Conditions Applicable to All Grants Agreements
<input checked="" type="checkbox"/> Attachment 2: Special Terms and Conditions
<input checked="" type="checkbox"/> Attachment 3: Grant Work Plan
<input checked="" type="checkbox"/> Attachment 4: Public Records Requirements
<input checked="" type="checkbox"/> Attachment 5: Special Audit Requirements
<input type="checkbox"/> Attachment 6: Program-Specific Requirements
<input type="checkbox"/> Attachment 7: Grant Award Terms (Federal) *Copy available at <a href="https://facts.fldfs.com">https://facts.fldfs.com</a> , in accordance with §215.985, F.S.
<input type="checkbox"/> Attachment 8: Federal Regulations and Terms (Federal)
<input type="checkbox"/> Additional Attachments (if necessary):
<input checked="" type="checkbox"/> Exhibit A: Progress Report Form
<input type="checkbox"/> Exhibit B: Property Reporting Form
<input checked="" type="checkbox"/> Exhibit C: Payment Request Summary Form
<input type="checkbox"/> Exhibit D: Quality Assurance Requirements
<input type="checkbox"/> Exhibit E: Advance Payment Terms and Interest Earned Memo
<input type="checkbox"/> Exhibit F: Common Carrier or Contracted Carrier Attestation Form PUR1808
<input type="checkbox"/> Additional Exhibits (if necessary):

8. The following information applies to Federal Grants only and is identified in accordance with 2 CFR 200.331 (a) (1):	
Federal Award Identification Number(s) (FAIN):	
Federal Award Date to Department:	
Total Federal Funds Obligated by this Agreement:	
Federal Awarding Agency:	
Award R&D?	<input type="checkbox"/> Yes <input type="checkbox"/> N/A

**IN WITNESS WHEREOF, this Agreement shall be effective on the date indicated by the Agreement Begin Date above or the last date signed below, whichever is later.**

Orange County \_\_\_\_\_ GRANTEE

By *Jerry L. Demings*  
(Authorized Signature)

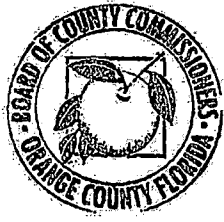

November 28, 2023  
Date Signed

**Jerry L. Demings, Orange County Mayor**  
Print Name and Title of Person Signing

State of Florida Department of Environmental Protection DEPARTMENT

By *Angela Knecht*  
Secretary or Designee

Digitally signed by Angela Knecht  
Date: 2023.12.07 16:20:25 -05'00'  
Date Signed

**Angela Knecht, Director, Division of Water Restoration Assistance**  
Print Name and Title of Person Signing

Additional signatures attached on separate page.

**DWRA Additional Signatures**

**Kate Pace**

Digitally signed by Kate Pace  
Date: 2023.12.07 07:34:41 -05'00'

Kate Pace, DEP Grant Manager

**Amanda Peck**

Digitally signed by Amanda Peck  
Date: 2023.12.07 16:14:29 -05'00'

Amanda Peck, DEP QC Reviewer

**Grantee Additional Signatures**

ORANGE COUNTY, FLORIDA

By: Board of County Commissioners

BY:

*Jerry L. Demings*

for Jerry L. Demings  
Orange County Mayor

DATE: November 28, 2023

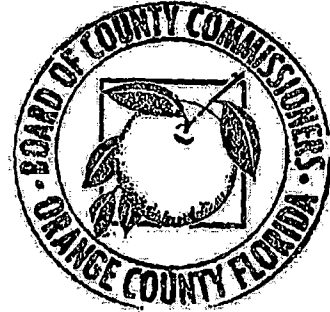

ATTEST: Phil Diamond, CPA, County Comptroller  
As Clerk of the Board of County Commissioners

BY:

*Jennifer Lara-Klimetz*

Deputy Clerk

Jennifer Lara-Klimetz

Printed Name



STATE OF FLORIDA  
DEPARTMENT OF ENVIRONMENTAL PROTECTION  
STANDARD TERMS AND CONDITIONS  
APPLICABLE TO GRANT AGREEMENTS

ATTACHMENT 1

**1. Entire Agreement.**

This Grant Agreement, including any Attachments and Exhibits referred to herein and/or attached hereto (Agreement), constitutes the entire agreement between the parties with respect to the subject matter hereof and supersedes all prior agreements, whether written or oral, with respect to such subject matter. Any terms and conditions included on Grantee's forms or invoices shall be null and void.

**2. Grant Administration.**

- a. Order of Precedence. If there are conflicting provisions among the documents that make up the Agreement, the order of precedence for interpretation of the Agreement is as follows:
- i. Standard Grant Agreement
  - ii. Attachments other than Attachment 1, in numerical order as designated in the Standard Grant Agreement
  - iii. Attachment 1, Standard Terms and Conditions
  - iv. The Exhibits in the order designated in the Standard Grant Agreement
- b. All approvals, written or verbal, and other written communication among the parties, including all notices, shall be obtained by or sent to the parties' Grant Managers. All written communication shall be by electronic mail, U.S. Mail, a courier delivery service, or delivered in person. Notices shall be considered delivered when reflected by an electronic mail read receipt, a courier service delivery receipt, other mail service delivery receipt, or when receipt is acknowledged by recipient. If the notice is delivered in multiple ways, the notice will be considered delivered at the earliest delivery time.
- c. If a different Grant Manager is designated by either party after execution of this Agreement, notice of the name and contact information of the new Grant Manager will be submitted in writing to the other party and maintained in the respective parties' records. A change of Grant Manager does not require a formal amendment or change order to the Agreement.
- d. This Agreement may be amended, through a formal amendment or a change order, only by a written agreement between both parties. A formal amendment to this Agreement is required for changes which cause any of the following:
- (1) an increase or decrease in the Agreement funding amount;
  - (2) a change in Grantee's match requirements;
  - (3) a change in the expiration date of the Agreement; and/or
  - (4) changes to the cumulative amount of funding transfers between approved budget categories, as defined in Attachment 3, Grant Work Plan, that exceeds or is expected to exceed twenty percent (20%) of the total budget as last approved by Department.
- A change order to this Agreement may be used when:
- (1) task timelines within the current authorized Agreement period change;
  - (2) the cumulative transfer of funds between approved budget categories, as defined in Attachment 3, Grant Work Plan, are less than twenty percent (20%) of the total budget as last approved by Department;
  - (3) changing the current funding source as stated in the Standard Grant Agreement; and/or
  - (4) fund transfers between budget categories for the purposes of meeting match requirements.
- This Agreement may be amended to provide for additional services if additional funding is made available by the Legislature.
- e. All days in this Agreement are calendar days unless otherwise specified.

**3. Agreement Duration.**

The term of the Agreement shall begin and end on the dates indicated in the Standard Grant Agreement, unless extended or terminated earlier in accordance with the applicable terms and conditions. The Grantee shall be eligible for reimbursement for work performed on or after the date of execution through the expiration date of this Agreement, unless otherwise specified in Attachment 2, Special Terms and Conditions. However, work performed prior to the execution of this Agreement may be reimbursable or used for match purposes if permitted by the Special Terms and Conditions.

#### **4. Deliverables.**

The Grantee agrees to render the services or other units of deliverables as set forth in Attachment 3, Grant Work Plan. The services or other units of deliverables shall be delivered in accordance with the schedule and at the pricing outlined in the Grant Work Plan. Deliverables may be comprised of activities that must be completed prior to Department making payment on that deliverable. The Grantee agrees to perform in accordance with the terms and conditions set forth in this Agreement and all attachments and exhibits incorporated by the Standard Grant Agreement.

#### **5. Performance Measures.**

The Grantee warrants that: (1) the services will be performed by qualified personnel; (2) the services will be of the kind and quality described in the Grant Work Plan; (3) the services will be performed in a professional and workmanlike manner in accordance with industry standards and practices; (4) the services shall not and do not knowingly infringe upon the intellectual property rights, or any other proprietary rights, of any third party; and (5) its employees, subcontractors, and/or subgrantees shall comply with any security and safety requirements and processes, if provided by Department, for work done at the Project Location(s). The Department reserves the right to investigate or inspect at any time to determine whether the services or qualifications offered by Grantee meet the Agreement requirements. Notwithstanding any provisions herein to the contrary, written acceptance of a particular deliverable does not foreclose Department's remedies in the event deficiencies in the deliverable cannot be readily measured at the time of delivery.

#### **6. Acceptance of Deliverables.**

- i. Acceptance Process. All deliverables must be received and accepted in writing by Department's Grant Manager before payment. The Grantee shall work diligently to correct all deficiencies in the deliverable that remain outstanding, within a reasonable time at Grantee's expense. If Department's Grant Manager does not accept the deliverables within 30 days of receipt, they will be deemed rejected.
- ii. Rejection of Deliverables. The Department reserves the right to reject deliverables, as outlined in the Grant Work Plan, as incomplete, inadequate, or unacceptable due, in whole or in part, to Grantee's lack of satisfactory performance under the terms of this Agreement. The Grantee's efforts to correct the rejected deliverables will be at Grantee's sole expense. Failure to fulfill the applicable technical requirements or complete all tasks or activities in accordance with the Grant Work Plan will result in rejection of the deliverable and the associated invoice. Payment for the rejected deliverable will not be issued unless the rejected deliverable is made acceptable to Department in accordance with the Agreement requirements. The Department, at its option, may allow additional time within which Grantee may remedy the objections noted by Department. The Grantee's failure to make adequate or acceptable deliverables after a reasonable opportunity to do so shall constitute an event of default.

#### **7. Financial Consequences for Nonperformance.**

- a. Withholding Payment. In addition to the specific consequences explained in the Grant Work Plan and/or Special Terms and Conditions, the State of Florida (State) reserves the right to withhold payment when the Grantee has failed to perform/comply with provisions of this Agreement. None of the financial consequences for nonperformance in this Agreement as more fully described in the Grant Work Plan shall be considered penalties.
- b. Invoice reduction  
If Grantee does not meet a deadline for any deliverable, the Department will reduce the invoice by 1% for each day the deadline is missed, unless an extension is approved in writing by the Department.
- c. Corrective Action Plan. If Grantee fails to correct all the deficiencies in a rejected deliverable within the specified timeframe, Department may, in its sole discretion, request that a proposed Corrective Action Plan (CAP) be submitted by Grantee to Department. The Department requests that Grantee specify the outstanding deficiencies in the CAP. All CAPs must be able to be implemented and performed in no more than sixty (60) calendar days.
  - i. The Grantee shall submit a CAP within ten (10) days of the date of the written request from Department. The CAP shall be sent to the Department's Grant Manager for review and approval. Within ten (10) days of receipt of a CAP, Department shall notify Grantee in writing whether the CAP proposed has been accepted. If the CAP is not accepted, Grantee shall have ten (10) days from receipt of Department letter rejecting the proposal to submit a revised proposed CAP. Failure to obtain Department approval of a CAP as specified above may result in Department's termination of this Agreement for cause as authorized in this Agreement.
  - ii. Upon Department's notice of acceptance of a proposed CAP, Grantee shall have ten (10) days to commence implementation of the accepted plan. Acceptance of the proposed CAP by Department does not relieve Grantee of any of its obligations under the Agreement. In the event the CAP fails to correct or eliminate performance deficiencies by Grantee, Department shall retain the right to



require additional or further remedial steps, or to terminate this Agreement for failure to perform. No actions approved by Department or steps taken by Grantee shall preclude Department from subsequently asserting any deficiencies in performance. The Grantee shall continue to implement the CAP until all deficiencies are corrected. Reports on the progress of the CAP will be made to Department as requested by Department's Grant Manager.

- iii. Failure to respond to a Department request for a CAP or failure to correct a deficiency in the performance of the Agreement as specified by Department may result in termination of the Agreement.

**8. Payment.**

- a. Payment Process. Subject to the terms and conditions established by the Agreement, the pricing per deliverable established by the Grant Work Plan, and the billing procedures established by Department, Department agrees to pay Grantee for services rendered in accordance with section 215.422, Florida Statutes (F.S.).
- b. Taxes. The Department is exempted from payment of State sales, use taxes and Federal excise taxes. The Grantee, however, shall not be exempted from paying any taxes that it is subject to, including State sales and use taxes, or for payment by Grantee to suppliers for taxes on materials used to fulfill its contractual obligations with Department. The Grantee shall not use Department's exemption number in securing such materials. The Grantee shall be responsible and liable for the payment of all its FICA/Social Security and other taxes resulting from this Agreement.
- c. Maximum Amount of Agreement. The maximum amount of compensation under this Agreement, without an amendment, is described in the Standard Grant Agreement. Any additional funds necessary for the completion of this Project are the responsibility of Grantee.
- d. Reimbursement for Costs. The Grantee shall be paid on a cost reimbursement basis for all eligible Project costs upon the completion, submittal, and approval of each deliverable identified in the Grant Work Plan. Reimbursement shall be requested on Exhibit C, Payment Request Summary Form. To be eligible for reimbursement, costs must be in compliance with laws, rules, and regulations applicable to expenditures of State funds, including, but not limited to, the Reference Guide for State Expenditures, which can be accessed at the following web address: <https://www.myfloridacfo.com/docs-sf/accounting-and-auditing-libraries/state-agencies/reference-guide-for-state-expenditures.pdf>.
- e. Invoice Detail. All charges for services rendered or for reimbursement of expenses authorized by Department pursuant to the Grant Work Plan shall be submitted to Department in sufficient detail for a proper pre-audit and post-audit to be performed. The Grantee shall only invoice Department for deliverables that are completed in accordance with the Grant Work Plan.
- f. State Funds Documentation. Pursuant to section 216.1366, F.S., if Contractor meets the definition of a non-profit organization under section 215.97(2)(m), F.S., Contractor must provide the Department with documentation that indicates the amount of state funds:
  - i. Allocated to be used during the full term of the contract or agreement for remuneration to any member of the board of directors or an officer of Contractor.
  - ii. Allocated under each payment by the public agency to be used for remuneration of any member of the board of directors or an officer of the Contractor.The documentation must indicate the amounts and recipients of the remuneration. Such information must be posted on the State's the contract tracking system and maintained pursuant to section 215.985, F.S., and must be posted on the Contractor's website, if Contractor maintains a website.
- g. Interim Payments. Interim payments may be made by Department, at its discretion, if the completion of deliverables to date have first been accepted in writing by Department's Grant Manager.
- h. Final Payment Request. A final payment request should be submitted to Department no later than sixty (60) days following the expiration date of the Agreement to ensure the availability of funds for payment. However, all work performed pursuant to the Grant Work Plan must be performed on or before the expiration date of the Agreement.
- i. Annual Appropriation Contingency. The State's performance and obligation to pay under this Agreement is contingent upon an annual appropriation by the Legislature. This Agreement is not a commitment of future appropriations. Authorization for continuation and completion of work and any associated payments may be rescinded, with proper notice, at the discretion of Department if the Legislature reduces or eliminates appropriations.
- j. Interest Rates. All interest rates charged under the Agreement shall be calculated on the prevailing rate used by the State Board of Administration. To obtain the applicable interest rate, please refer to: [www.myfloridacfo.com/Division/AA/Vendors/default.htm](http://www.myfloridacfo.com/Division/AA/Vendors/default.htm).

- k. Refund of Payments to the Department. Any balance of unobligated funds that have been advanced or paid must be refunded to Department. Any funds paid in excess of the amount to which Grantee or subgrantee is entitled under the terms of the Agreement must be refunded to Department. If this Agreement is funded with federal funds and the Department is required to refund the federal government, the Grantee shall refund the Department its share of those funds.

**9. Documentation Required for Cost Reimbursement Grant Agreements and Match.**

If Cost Reimbursement or Match is authorized in Attachment 2, Special Terms and Conditions, the following conditions apply. Supporting documentation must be provided to substantiate cost reimbursement or match requirements for the following budget categories:

- a. Salary/Wages. Grantee shall list personnel involved, position classification, direct salary rates, and hours spent on the Project in accordance with Attachment 3, Grant Work Plan in their documentation for reimbursement or match requirements.
- b. Overhead/Indirect/General and Administrative Costs. If Grantee is being reimbursed for or claiming match for multipliers, all multipliers used (i.e., fringe benefits, overhead, indirect, and/or general and administrative rates) shall be supported by audit. If Department determines that multipliers charged by Grantee exceeded the rates supported by audit, Grantee shall be required to reimburse such funds to Department within thirty (30) days of written notification. Interest shall be charged on the excessive rate.
- c. Contractual Costs (Subcontractors). Match or reimbursement requests for payments to subcontractors must be substantiated by copies of invoices with backup documentation identical to that required from Grantee. Subcontracts which involve payments for direct salaries shall clearly identify the personnel involved, salary rate per hour, and hours spent on the Project. All eligible multipliers used (i.e., fringe benefits, overhead, indirect, and/or general and administrative rates) shall be supported by audit. If Department determines that multipliers charged by any subcontractor exceeded the rates supported by audit, Grantee shall be required to reimburse such funds to Department within thirty (30) days of written notification. Interest shall be charged on the excessive rate. Nonconsumable and/or nonexpendable personal property or equipment costing \$5,000 or more purchased for the Project under a subcontract is subject to the requirements set forth in chapters 273 and/or 274, F.S., and Chapter 69I-72, Florida Administrative Code (F.A.C.) and/or Chapter 69I-73, F.A.C., as applicable. The Grantee shall be responsible for maintaining appropriate property records for any subcontracts that include the purchase of equipment as part of the delivery of services. The Grantee shall comply with this requirement and ensure its subcontracts issued under this Agreement, if any, impose this requirement, in writing, on its subcontractors.
- i. For fixed-price (vendor) subcontracts, the following provisions shall apply: The Grantee may award, on a competitive basis, fixed-price subcontracts to consultants/contractors in performing the work described in Attachment 3, Grant Work Plan. Invoices submitted to Department for fixed-price subcontracted activities shall be supported with a copy of the subcontractor's invoice and a copy of the tabulation form for the competitive procurement process (e.g., Invitation to Bid, Request for Proposals, or other similar competitive procurement document) resulting in the fixed-price subcontract. The Grantee may request approval from Department to award a fixed-price subcontract resulting from procurement methods other than those identified above. In this instance, Grantee shall request the advance written approval from Department's Grant Manager of the fixed price negotiated by Grantee. The letter of request shall be supported by a detailed budget and Scope of Services to be performed by the subcontractor. Upon receipt of Department Grant Manager's approval of the fixed-price amount, Grantee may proceed in finalizing the fixed-price subcontract.
- ii. If the procurement is subject to the Consultant's Competitive Negotiation Act under section 287.055, F.S. or the Brooks Act, Grantee must provide documentation clearly evidencing it has complied with the statutory or federal requirements.
- d. Travel. All requests for match or reimbursement of travel expenses shall be in accordance with section 112.061, F.S.
- e. Direct Purchase Equipment. For the purposes of this Agreement, Equipment is defined as capital outlay costing \$5,000 or more. Match or reimbursement for Grantee's direct purchase of equipment is subject to specific approval of Department, and does not include any equipment purchased under the delivery of services to be completed by a subcontractor. Include copies of invoices or receipts to document purchases, and a properly completed Exhibit B, Property Reporting Form.
- f. Rental/Lease of Equipment. Match or reimbursement requests for rental/lease of equipment must include copies of invoices or receipts to document charges.
- g. Miscellaneous/Other Expenses. If miscellaneous or other expenses, such as materials, supplies, non-excluded phone expenses, reproduction, or mailing, are reimbursable or available for match or reimbursement under the

terms of this Agreement, the documentation supporting these expenses must be itemized and include copies of receipts or invoices. Additionally, independent of Grantee's contract obligations to its subcontractor, Department shall not reimburse any of the following types of charges: cell phone usage; attorney's fees or court costs; civil or administrative penalties; or handling fees, such as set percent overages associated with purchasing supplies or equipment.

- h. Land Acquisition. Reimbursement for the costs associated with acquiring interest and/or rights to real property (including access rights through ingress/egress easements, leases, license agreements, or other site access agreements; and/or obtaining record title ownership of real property through purchase) must be supported by the following, as applicable: Copies of Property Appraisals, Environmental Site Assessments, Surveys and Legal Descriptions, Boundary Maps, Acreage Certification, Title Search Reports, Title Insurance, Closing Statements/Documents, Deeds, Leases, Easements, License Agreements, or other legal instrument documenting acquired property interest and/or rights. If land acquisition costs are used to meet match requirements, Grantee agrees that those funds shall not be used as match for any other Agreement supported by State or Federal funds.

#### **10. Status Reports.**

The Grantee shall submit status reports quarterly, unless otherwise specified in the Attachments, on Exhibit A, Progress Report Form, to Department's Grant Manager describing the work performed during the reporting period, problems encountered, problem resolutions, scheduled updates, and proposed work for the next reporting period. Quarterly status reports are due no later than twenty (20) days following the completion of the quarterly reporting period. For the purposes of this reporting requirement, the quarterly reporting periods end on March 31, June 30, September 30 and December 31. The Department will review the required reports submitted by Grantee within thirty (30) days.

#### **11. Retainage.**

The following provisions apply if Department withholds retainage under this Agreement:

- a. The Department reserves the right to establish the amount and application of retainage on the work performed under this Agreement up to the maximum percentage described in Attachment 2, Special Terms and Conditions. Retainage may be withheld from each payment to Grantee pending satisfactory completion of work and approval of all deliverables.
- b. If Grantee fails to perform the requested work or fails to perform the work in a satisfactory manner, Grantee shall forfeit its right to payment of the retainage associated with the work. Failure to perform includes, but is not limited to, failure to submit the required deliverables or failure to provide adequate documentation that the work was actually performed. The Department shall provide written notification to Grantee of the failure to perform that shall result in retainage forfeiture. If the Grantee does not correct the failure to perform within the timeframe stated in Department's notice, the retainage will be forfeited to Department.
- c. No retainage shall be released or paid for incomplete work while this Agreement is suspended.
- d. Except as otherwise provided above, Grantee shall be paid the retainage associated with the work, provided Grantee has completed the work and submits an invoice for retainage held in accordance with the invoicing procedures under this Agreement.

#### **12. Insurance.**

- a. Insurance Requirements for Sub-Grantees and/or Subcontractors. The Grantee shall require its sub-grantees and/or subcontractors, if any, to maintain insurance coverage of such types and with such terms and limits as described in this Agreement. The Grantee shall require all its sub-grantees and/or subcontractors, if any, to make compliance with the insurance requirements of this Agreement a condition of all contracts that are related to this Agreement. Sub-grantees and/or subcontractors must provide proof of insurance upon request.
- b. Deductibles. The Department shall be exempt from, and in no way liable for, any sums of money representing a deductible in any insurance policy. The payment of such deductible shall be the sole responsibility of the Grantee providing such insurance.
- c. Proof of Insurance. Upon execution of this Agreement, Grantee shall provide Department documentation demonstrating the existence and amount for each type of applicable insurance coverage *prior to* performance of any work under this Agreement. Upon receipt of written request from Department, Grantee shall furnish Department with proof of applicable insurance coverage by standard form certificates of insurance, a self-insured authorization, or other certification of self-insurance.
- d. Duty to Maintain Coverage. In the event that any applicable coverage is cancelled by the insurer for any reason, or if Grantee cannot get adequate coverage, Grantee shall immediately notify Department of such cancellation and shall obtain adequate replacement coverage conforming to the requirements herein and provide proof of such replacement coverage within ten (10) days after the cancellation of coverage.

- e. Insurance Trust. If the Grantee's insurance is provided through an insurance trust, the Grantee shall instead add the Department of Environmental Protection, its employees, and officers as an additional covered party everywhere the Agreement requires them to be added as an additional insured.

**13. Termination.**

- i. Termination for Convenience. When it is in the State's best interest, Department may, at its sole discretion, terminate the Agreement in whole or in part by giving 30 days' written notice to Grantee. The Department shall notify Grantee of the termination for convenience with instructions as to the effective date of termination or the specific stage of work at which the Agreement is to be terminated. The Grantee must submit all invoices for work to be paid under this Agreement within thirty (30) days of the effective date of termination. The Department shall not pay any invoices received after thirty (30) days of the effective date of termination.
- ii. Termination for Cause. The Department may terminate this Agreement if any of the events of default described in the Events of Default provisions below occur or in the event that Grantee fails to fulfill any of its other obligations under this Agreement. If, after termination, it is determined that Grantee was not in default, or that the default was excusable, the rights and obligations of the parties shall be the same as if the termination had been issued for the convenience of Department. The rights and remedies of Department in this clause are in addition to any other rights and remedies provided by law or under this Agreement.
- iii. Grantee Obligations upon Notice of Termination. After receipt of a notice of termination or partial termination unless as otherwise directed by Department, Grantee shall not furnish any service or deliverable on the date, and to the extent specified, in the notice. However, Grantee shall continue work on any portion of the Agreement not terminated. If the Agreement is terminated before performance is completed, Grantee shall be paid only for that work satisfactorily performed for which costs can be substantiated. The Grantee shall not be entitled to recover any cancellation charges or lost profits.
- iv. Continuation of Prepaid Services. If Department has paid for any services prior to the expiration, cancellation, or termination of the Agreement, Grantee shall continue to provide Department with those services for which it has already been paid or, at Department's discretion, Grantee shall provide a refund for services that have been paid for but not rendered.
- v. Transition of Services Upon Termination, Expiration, or Cancellation of the Agreement. If services provided under the Agreement are being transitioned to another provider(s), Grantee shall assist in the smooth transition of Agreement services to the subsequent provider(s). This requirement is at a minimum an affirmative obligation to cooperate with the new provider(s), however additional requirements may be outlined in the Grant Work Plan. The Grantee shall not perform any services after Agreement expiration or termination, except as necessary to complete the transition or continued portion of the Agreement, if any.

**14. Notice of Default.**

If Grantee defaults in the performance of any covenant or obligation contained in the Agreement, including, any of the events of default, Department shall provide notice to Grantee and an opportunity to cure that is reasonable under the circumstances. This notice shall state the nature of the failure to perform and provide a time certain for correcting the failure. The notice will also provide that, should the Grantee fail to perform within the time provided, Grantee will be found in default, and Department may terminate the Agreement effective as of the date of receipt of the default notice.

**15. Events of Default.**

Provided such failure is not the fault of Department or outside the reasonable control of Grantee, the following non-exclusive list of events, acts, or omissions, shall constitute events of default:

- a. The commitment of any material breach of this Agreement by Grantee, including failure to timely deliver a material deliverable, failure to perform the minimal level of services required for a deliverable, discontinuance of the performance of the work, failure to resume work that has been discontinued within a reasonable time after notice to do so, or abandonment of the Agreement;
- b. The commitment of any material misrepresentation or omission in any materials, or discovery by the Department of such, made by the Grantee in this Agreement or in its application for funding;
- c. Failure to submit any of the reports required by this Agreement or having submitted any report with incorrect, incomplete, or insufficient information;
- d. Failure to honor any term of the Agreement;
- e. Failure to abide by any statutory, regulatory, or licensing requirement, including an entry of an order revoking the certificate of authority granted to the Grantee by a state or other licensing authority;
- f. Failure to pay any and all entities, individuals, and furnishing labor or materials, or failure to make payment to any other entities as required by this Agreement;

- g. Employment of an unauthorized alien in the performance of the work, in violation of Section 274 (A) of the Immigration and Nationality Act;
- h. Failure to maintain the insurance required by this Agreement;
- i. One or more of the following circumstances, uncorrected for more than thirty (30) days unless, within the specified 30-day period, Grantee (including its receiver or trustee in bankruptcy) provides to Department adequate assurances, reasonably acceptable to Department, of its continuing ability and willingness to fulfill its obligations under the Agreement:
  - i. Entry of an order for relief under Title 11 of the United States Code;
  - ii. The making by Grantee of a general assignment for the benefit of creditors;
  - iii. The appointment of a general receiver or trustee in bankruptcy of Grantee's business or property; and/or
  - iv. An action by Grantee under any state insolvency or similar law for the purpose of its bankruptcy, reorganization, or liquidation.

#### **16. Suspension of Work.**

The Department may, in its sole discretion, suspend any or all activities under the Agreement, at any time, when it is in the best interest of the State to do so. The Department shall provide Grantee written notice outlining the particulars of suspension. Examples of reasons for suspension include, but are not limited to, budgetary constraints, declaration of emergency, or other such circumstances. After receiving a suspension notice, Grantee shall comply with the notice. Within 90 days, or any longer period agreed to by the parties, Department shall either: (1) issue a notice authorizing resumption of work, at which time activity shall resume; or (2) terminate the Agreement. If the Agreement is terminated after 30 days of suspension, the notice of suspension shall be deemed to satisfy the thirty (30) days' notice required for a notice of termination for convenience. Suspension of work shall not entitle Grantee to any additional compensation.

#### **17. Force Majeure.**

The Grantee shall not be responsible for delay resulting from its failure to perform if neither the fault nor the negligence of Grantee or its employees or agents contributed to the delay and the delay is due directly to acts of God, wars, acts of public enemies, strikes, fires, floods, or other similar cause wholly beyond Grantee's control, or for any of the foregoing that affect subcontractors or suppliers if no alternate source of supply is available to Grantee. In case of any delay Grantee believes is excusable, Grantee shall notify Department in writing of the delay or potential delay and describe the cause of the delay either (1) within ten days after the cause that creates or will create the delay first arose, if Grantee could reasonably foresee that a delay could occur as a result; or (2) if delay is not reasonably foreseeable, within five days after the date Grantee first had reason to believe that a delay could result. **THE FOREGOING SHALL CONSTITUTE THE GRANTEE'S SOLE REMEDY OR EXCUSE WITH RESPECT TO DELAY.** Providing notice in strict accordance with this paragraph is a condition precedent to such remedy. No claim for damages, other than for an extension of time, shall be asserted against Department. The Grantee shall not be entitled to an increase in the Agreement price or payment of any kind from Department for direct, indirect, consequential, impact or other costs, expenses or damages, including but not limited to costs of acceleration or inefficiency, arising because of delay, disruption, interference, or hindrance from any cause whatsoever. If performance is suspended or delayed, in whole or in part, due to any of the causes described in this paragraph, after the causes have ceased to exist Grantee shall perform at no increased cost, unless Department determines, in its sole discretion, that the delay will significantly impair the value of the Agreement to Department, in which case Department may: (1) accept allocated performance or deliveries from Grantee, provided that Grantee grants preferential treatment to Department with respect to products subjected to allocation; (2) contract with other sources (without recourse to and by Grantee for the related costs and expenses) to replace all or part of the products or services that are the subject of the delay, which purchases may be deducted from the Agreement quantity; or (3) terminate Agreement in whole or in part.

#### **18. Indemnification.**

- a. The Grantee shall be fully liable for the actions of its agents, employees, partners, or subcontractors and shall fully indemnify, defend, and hold harmless Department and its officers, agents, and employees, from suits, actions, damages, and costs of every name and description arising from or relating to:
  - i. personal injury and damage to real or personal tangible property alleged to be caused in whole or in part by Grantee, its agents, employees, partners, or subcontractors; provided, however, that Grantee shall not indemnify for that portion of any loss or damages proximately caused by the negligent act or omission of Department;
  - ii. the Grantee's breach of this Agreement or the negligent acts or omissions of Grantee.



- b. The Grantee's obligations under the preceding paragraph with respect to any legal action are contingent upon Department giving Grantee: (1) written notice of any action or threatened action; (2) the opportunity to take over and settle or defend any such action at Grantee's sole expense; and (3) assistance in defending the action at Grantee's sole expense. The Grantee shall not be liable for any cost, expense, or compromise incurred or made by Department in any legal action without Grantee's prior written consent, which shall not be unreasonably withheld.
- c. Notwithstanding sections a. and b. above, the following is the sole indemnification provision that applies to Grantees that are governmental entities: Each party hereto agrees that it shall be solely responsible for the negligent or wrongful acts of its employees and agents. However, nothing contained herein shall constitute a waiver by either party of its sovereign immunity or the provisions of section 768.28, F.S. Further, nothing herein shall be construed as consent by a state agency or subdivision of the State to be sued by third parties in any matter arising out of any contract or this Agreement.
- d. No provision in this Agreement shall require Department to hold harmless or indemnify Grantee, insure or assume liability for Grantee's negligence, waive Department's sovereign immunity under the laws of Florida, or otherwise impose liability on Department for which it would not otherwise be responsible. Any provision, implication or suggestion to the contrary is null and void.

**19. Limitation of Liability.**

The Department's liability for any claim arising from this Agreement is limited to compensatory damages in an amount no greater than the sum of the unpaid balance of compensation due for goods or services rendered pursuant to and in compliance with the terms of the Agreement. Such liability is further limited to a cap of \$100,000.

**20. Remedies.**

Nothing in this Agreement shall be construed to make Grantee liable for force majeure events. Nothing in this Agreement, including financial consequences for nonperformance, shall limit Department's right to pursue its remedies for other types of damages under the Agreement, at law or in equity. The Department may, in addition to other remedies available to it, at law or in equity and upon notice to Grantee, retain such monies from amounts due Grantee as may be necessary to satisfy any claim for damages, penalties, costs and the like asserted by or against it.

**21. Waiver.**

The delay or failure by Department to exercise or enforce any of its rights under this Agreement shall not constitute or be deemed a waiver of Department's right thereafter to enforce those rights, nor shall any single or partial exercise of any such right preclude any other or further exercise thereof or the exercise of any other right.

**22. Statutory Notices Relating to Unauthorized Employment and Subcontracts.**

- a. The Department shall consider the employment by any Grantee of unauthorized aliens a violation of Section 274A(e) of the Immigration and Nationality Act. If Grantee/subcontractor knowingly employs unauthorized aliens, such violation shall be cause for unilateral cancellation of this Agreement. The Grantee shall be responsible for including this provision in all subcontracts with private organizations issued as a result of this Agreement.
- b. Pursuant to sections 287.133, 287.134, and 287.137 F.S., the following restrictions apply to persons placed on the convicted vendor list, discriminatory vendor list, or the antitrust violator vendor list:
  - i. Public Entity Crime. A person or affiliate who has been placed on the convicted vendor list following a conviction for a public entity crime may not submit a bid, proposal, or reply on a contract to provide any goods or services to a public entity; may not submit a bid, proposal, or reply on a contract with a public entity for the construction or repair of a public building or public work; may not submit bids, proposals, or replies on leases of real property to a public entity; may not be awarded or perform work as a Grantee, supplier, subcontractor, or consultant under a contract with any public entity; and may not transact business with any public entity in excess of the threshold amount provided in section 287.017, F.S., for CATEGORY TWO for a period of 36 months following the date of being placed on the convicted vendor list.
  - ii. Discriminatory Vendors. An entity or affiliate who has been placed on the discriminatory vendor list may not submit a bid, proposal, or reply on a contract to provide any goods or services to a public entity; may not submit a bid, proposal, or reply on a contract with a public entity for the construction or repair of a public building or public work; may not submit bids, proposals, or replies on leases of real property to a public entity; may not be awarded or perform work as a contractor, supplier, subcontractor, or consultant under a contract with any public entity; and may not transact business with any public entity.
  - iii. Antitrust Violator Vendors. A person or an affiliate who has been placed on the antitrust violator vendor list following a conviction or being held civilly liable for an antitrust violation may not submit a bid, proposal, or reply on any contract to provide any good or services to a public entity;



may not submit a bid, proposal, or reply on any contract with a public entity for the construction or repair of a public building or public work; may not submit a bid, proposal, or reply on leases of real property to a public entity; may not be awarded or perform work as a Grantee, supplier, subcontractor, or consultant under a contract with a public entity; and may not transact new business with a public entity.

- iv. **Notification.** The Grantee shall notify Department if it or any of its suppliers, subcontractors, or consultants have been placed on the convicted vendor list, the discriminatory vendor list, or antitrust violator vendor list during the life of the Agreement. The Florida Department of Management Services is responsible for maintaining the discriminatory vendor list and the antitrust violator vendor list and posts the list on its website. Questions regarding the discriminatory vendor list or antitrust violator vendor list may be directed to the Florida Department of Management Services, Office of Supplier Diversity, at (850) 487-0915.

**23. Compliance with Federal, State and Local Laws.**

- a. The Grantee and all its agents shall comply with all federal, state and local regulations, including, but not limited to, nondiscrimination, wages, social security, workers' compensation, licenses, and registration requirements. The Grantee shall include this provision in all subcontracts issued as a result of this Agreement.
- b. No person, on the grounds of race, creed, color, religion, national origin, age, gender, or disability, shall be excluded from participation in; be denied the proceeds or benefits of; or be otherwise subjected to discrimination in performance of this Agreement.
- c. This Agreement shall be governed by and construed in accordance with the laws of the State of Florida.
- d. Any dispute concerning performance of the Agreement shall be processed as described herein. Jurisdiction for any damages arising under the terms of the Agreement will be in the courts of the State, and venue will be in the Second Judicial Circuit, in and for Leon County. Except as otherwise provided by law, the parties agree to be responsible for their own attorney fees incurred in connection with disputes arising under the terms of this Agreement.

**24. Build America, Buy America Act (BABA) - Infrastructure Projects with Federal Funding.**

**This provision does not apply to Agreements that are wholly funded by Coronavirus State and Local Fiscal Recovery Funds under the American Rescue Plan Act. Also, this provision does not apply where there is a valid waiver in place. However, the provision may apply to funds expended before the waiver or after expiration of the waiver.**

If applicable, Recipients or Subrecipients of an award of Federal financial assistance from a program for infrastructure are required to comply with the Build America, Buy America Act (BABA), including the following provisions:

- a. All iron and steel used in the project are produced in the United States--this means all manufacturing processes, from the initial melting stage through the application of coatings, occurred in the United States;
- b. All manufactured products used in the project are produced in the United States--this means the manufactured product was manufactured in the United States; and the cost of the components of the manufactured product that are mined, produced, or manufactured in the United States is greater than 55 percent of the total cost of all components of the manufactured product, unless another standard for determining the minimum amount of domestic content of the manufactured product has been established under applicable law or regulation; and
- c. All construction materials are manufactured in the United States--this means that all manufacturing processes for the construction material occurred in the United States.

The Buy America preference only applies to articles, materials, and supplies that are consumed in, incorporated into, or affixed to an infrastructure project. As such, it does not apply to tools, equipment, and supplies, such as temporary scaffolding, brought to the construction site and removed at or before the completion of the infrastructure project. Nor does a Buy America preference apply to equipment and furnishings, such as movable chairs, desks, and portable computer equipment, that are used at or within the finished infrastructure project but are not an integral part of the structure or permanently affixed to the infrastructure project.

**25. Investing in America**

Grantees of an award for construction projects in whole or in part by the Bipartisan Infrastructure Law or the Inflation Reduction Act, including the following provision:

- i. **Signage Requirements**
  - a. **Investing in America Emblem:** The recipient will ensure that a sign is placed at construction sites supported in whole or in part by this award displaying the official Investing in America emblem and must identify the project as a "project funded by President Biden's Bipartisan

Infrastructure Law” or “project funded by President Biden’s Inflation Reduction Act” as applicable. The sign must be placed at construction sites in an easily visible location that can be directly linked to the work taking place and must be maintained in good condition throughout the construction period.

The recipient will ensure compliance with the guidelines and design specifications provided by EPA for using the official Investing in America emblem available at:

<https://www.epa.gov/invest/investing-america-signage>.

b. Procuring Signs: Consistent with section 6002 of RCRA, 42 U.S.C. 6962, and 2 CFR 200.323, recipients are encouraged to use recycled or recovered materials when procuring signs. Signage costs are considered an allowable cost under this assistance agreement provided that the costs associated with signage are reasonable. Additionally, to increase public awareness of projects serving communities where English is not the predominant language, recipients are encouraged to translate the language on signs (excluding the official Investing in America emblem or EPA logo or seal) into the appropriate non-English language(s). The costs of such translation are allowable, provided the costs are reasonable.

## **26. Scrutinized Companies.**

- i. Grantee certifies that it is not on the Scrutinized Companies that Boycott Israel List or engaged in a boycott of Israel. Pursuant to section 287.135, F.S., the Department may immediately terminate this Agreement at its sole option if the Grantee is found to have submitted a false certification; or if the Grantee is placed on the Scrutinized Companies that Boycott Israel List or is engaged in the boycott of Israel during the term of the Agreement.
- ii. If this Agreement is for more than one million dollars, the Grantee certifies that it is also not on the Scrutinized Companies with Activities in Sudan, Scrutinized Companies with Activities in the Iran Petroleum Energy Sector List, or engaged with business operations in Cuba or Syria as identified in section 287.135, F.S. Pursuant to section 287.135, F.S., the Department may immediately terminate this Agreement at its sole option if the Grantee is found to have submitted a false certification; or if the Grantee is placed on the Scrutinized Companies with Activities in Sudan List, or Scrutinized Companies with Activities in the Iran Petroleum Energy Sector List, or engaged with business operations in Cuba or Syria during the term of the Agreement.
- iii. As provided in subsection 287.135(8), F.S., if federal law ceases to authorize these contracting prohibitions, then they shall become inoperative.

## **27. Lobbying and Integrity.**

The Grantee agrees that no funds received by it under this Agreement will be expended for the purpose of lobbying the Legislature or a State agency pursuant to section 216.347, F.S., except that pursuant to the requirements of section 287.058(6), F.S., during the term of any executed agreement between Grantee and the State, Grantee may lobby the executive or legislative branch concerning the scope of services, performance, term, or compensation regarding that agreement. The Grantee shall comply with sections 11.062 and 216.347, F.S.

## **28. Record Keeping.**

The Grantee shall maintain books, records and documents directly pertinent to performance under this Agreement in accordance with United States generally accepted accounting principles (US GAAP) consistently applied. The Department, the State, or their authorized representatives shall have access to such records for audit purposes during the term of this Agreement and for five (5) years following the completion date or termination of the Agreement. In the event that any work is subcontracted, Grantee shall similarly require each subcontractor to maintain and allow access to such records for audit purposes. Upon request of Department’s Inspector General, or other authorized State official, Grantee shall provide any type of information the Inspector General deems relevant to Grantee’s integrity or responsibility. Such information may include, but shall not be limited to, Grantee’s business or financial records, documents, or files of any type or form that refer to or relate to Agreement. The Grantee shall retain such records for the longer of: (1) three years after the expiration of the Agreement; or (2) the period required by the General Records Schedules maintained by the Florida Department of State (available at:

<http://dos.myflorida.com/library-archives/records-management/general-records-schedules/>).

## **29. Audits.**

- a. Inspector General. The Grantee understands its duty, pursuant to section 20.055(5), F.S., to cooperate with the inspector general in any investigation, audit, inspection, review, or hearing. The Grantee will comply with this duty and ensure that its sub-grantees and/or subcontractors issued under this Agreement, if any, impose this requirement, in writing, on its sub-grantees and/or subcontractors, respectively.

- b. Physical Access and Inspection. Department personnel shall be given access to and may observe and inspect work being performed under this Agreement, with reasonable notice and during normal business hours, including by any of the following methods:
- i. Grantee shall provide access to any location or facility on which Grantee is performing work, or storing or staging equipment, materials or documents;
  - ii. Grantee shall permit inspection of any facility, equipment, practices, or operations required in performance of any work pursuant to this Agreement; and,
  - iii. Grantee shall allow and facilitate sampling and monitoring of any substances, soils, materials or parameters at any location reasonable or necessary to assure compliance with any work or legal requirements pursuant to this Agreement.
- c. Special Audit Requirements. The Grantee shall comply with the applicable provisions contained in Attachment 5, Special Audit Requirements. Each amendment that authorizes a funding increase or decrease shall include an updated copy of Exhibit 1, to Attachment 5. If Department fails to provide an updated copy of Exhibit 1 to include in each amendment that authorizes a funding increase or decrease, Grantee shall request one from the Department's Grants Manager. The Grantee shall consider the type of financial assistance (federal and/or state) identified in Attachment 5, Exhibit 1 and determine whether the terms of Federal and/or Florida Single Audit Act Requirements may further apply to lower tier transactions that may be a result of this Agreement. For federal financial assistance, Grantee shall utilize the guidance provided under 2 CFR §200.331 for determining whether the relationship represents that of a subrecipient or vendor. For State financial assistance, Grantee shall utilize the form entitled "Checklist for Nonstate Organizations Recipient/Subrecipient vs Vendor Determination" (form number DFS-A2-NS) that can be found under the "Links/Forms" section appearing at the following website: <https://apps.fldfs.com/vfsaa>.
- d. Proof of Transactions. In addition to documentation provided to support cost reimbursement as described herein, Department may periodically request additional proof of a transaction to evaluate the appropriateness of costs to the Agreement pursuant to State guidelines (including cost allocation guidelines) and federal, if applicable. Allowable costs and uniform administrative requirements for federal programs can be found under 2 CFR 200. The Department may also request a cost allocation plan in support of its multipliers (overhead, indirect, general administrative costs, and fringe benefits). The Grantee must provide the additional proof within thirty (30) days of such request.
- e. No Commingling of Funds. The accounting systems for all Grantees must ensure that these funds are not commingled with funds from other agencies. Funds from each agency must be accounted for separately. Grantees are prohibited from commingling funds on either a program-by-program or a project-by-project basis. Funds specifically budgeted and/or received for one project may not be used to support another project. Where a Grantee's, or subrecipient's, accounting system cannot comply with this requirement, Grantee, or subrecipient, shall establish a system to provide adequate fund accountability for each project it has been awarded.
- i. If Department finds that these funds have been commingled, Department shall have the right to demand a refund, either in whole or in part, of the funds provided to Grantee under this Agreement for non-compliance with the material terms of this Agreement. The Grantee, upon such written notification from Department shall refund, and shall forthwith pay to Department, the amount of money demanded by Department. Interest on any refund shall be calculated based on the prevailing rate used by the State Board of Administration. Interest shall be calculated from the date(s) the original payment(s) are received from Department by Grantee to the date repayment is made by Grantee to Department.
  - ii. In the event that the Grantee recovers costs, incurred under this Agreement and reimbursed by Department, from another source(s), Grantee shall reimburse Department for all recovered funds originally provided under this Agreement and interest shall be charged for those recovered costs as calculated on from the date(s) the payment(s) are recovered by Grantee to the date repayment is made to Department.
  - iii. Notwithstanding the requirements of this section, the above restrictions on commingling funds do not apply to agreements where payments are made purely on a cost reimbursement basis.

**30. Conflict of Interest.**

The Grantee covenants that it presently has no interest and shall not acquire any interest which would conflict in any manner or degree with the performance of services required.

**31. Independent Contractor.**

The Grantee is an independent contractor and is not an employee or agent of Department.

**32. Subcontracting.**

- a. Unless otherwise specified in the Special Terms and Conditions, all services contracted for are to be performed solely by Grantee.
- b. The Department may, for cause, require the replacement of any Grantee employee, subcontractor, or agent. For cause, includes, but is not limited to, technical or training qualifications, quality of work, change in security status, or non-compliance with an applicable Department policy or other requirement.
- c. The Department may, for cause, deny access to Department's secure information or any facility by any Grantee employee, subcontractor, or agent.
- d. The Department's actions under paragraphs b. or c. shall not relieve Grantee of its obligation to perform all work in compliance with the Agreement. The Grantee shall be responsible for the payment of all monies due under any subcontract. The Department shall not be liable to any subcontractor for any expenses or liabilities incurred under any subcontract and Grantee shall be solely liable to the subcontractor for all expenses and liabilities incurred under any subcontract.
- e. The Department will not deny Grantee's employees, subcontractors, or agents access to meetings within the Department's facilities, unless the basis of Department's denial is safety or security considerations.
- f. The Department supports diversity in its procurement program and requests that all subcontracting opportunities afforded by this Agreement embrace diversity enthusiastically. The award of subcontracts should reflect the full diversity of the citizens of the State. A list of minority-owned firms that could be offered subcontracting opportunities may be obtained by contacting the Office of Supplier Diversity at (850) 487-0915.
- g. The Grantee shall not be liable for any excess costs for a failure to perform, if the failure to perform is caused by the default of a subcontractor at any tier, and if the cause of the default is completely beyond the control of both Grantee and the subcontractor(s), and without the fault or negligence of either, unless the subcontracted products or services were obtainable from other sources in sufficient time for Grantee to meet the required delivery schedule.

### **33. Guarantee of Parent Company.**

If Grantee is a subsidiary of another corporation or other business entity, Grantee asserts that its parent company will guarantee all of the obligations of Grantee for purposes of fulfilling the obligations of Agreement. In the event Grantee is sold during the period the Agreement is in effect, Grantee agrees that it will be a requirement of sale that the new parent company guarantee all of the obligations of Grantee.

### **34. Survival.**

The respective obligations of the parties, which by their nature would continue beyond the termination or expiration of this Agreement, including without limitation, the obligations regarding confidentiality, proprietary interests, and public records, shall survive termination, cancellation, or expiration of this Agreement.

### **35. Third Parties.**

The Department shall not be deemed to assume any liability for the acts, failures to act or negligence of Grantee, its agents, servants, and employees, nor shall Grantee disclaim its own negligence to Department or any third party. This Agreement does not and is not intended to confer any rights or remedies upon any person other than the parties. If Department consents to a subcontract, Grantee will specifically disclose that this Agreement does not create any third-party rights. Further, no third parties shall rely upon any of the rights and obligations created under this Agreement.

### **36. Severability.**

If a court of competent jurisdiction deems any term or condition herein void or unenforceable, the other provisions are severable to that void provision, and shall remain in full force and effect.

### **37. Grantee's Employees, Subcontractors and Agents.**

All Grantee employees, subcontractors, or agents performing work under the Agreement shall be properly trained technicians who meet or exceed any specified training qualifications. Upon request, Grantee shall furnish a copy of technical certification or other proof of qualification. All employees, subcontractors, or agents performing work under Agreement must comply with all security and administrative requirements of Department and shall comply with all controlling laws and regulations relevant to the services they are providing under the Agreement.

### **38. Assignment.**

The Grantee shall not sell, assign, or transfer any of its rights, duties, or obligations under the Agreement, or under any purchase order issued pursuant to the Agreement, without the prior written consent of Department. In the event of any assignment, Grantee remains secondarily liable for performance of the Agreement, unless Department expressly waives such secondary liability. The Department may assign the Agreement with prior written notice to Grantee of its intent to do so.

### **39. Compensation Report.**

If this Agreement is a sole-source, public-private agreement or if the Grantee, through this agreement with the State, annually receive 50% or more of their budget from the State or from a combination of State and Federal funds, the

Grantee shall provide an annual report, including the most recent IRS Form 990, detailing the total compensation for the entities' executive leadership teams. Total compensation shall include salary, bonuses, cashed-in leave, cash equivalents, severance pay, retirement benefits, deferred compensation, real-property gifts, and any other payout. The Grantee must also inform the Department of any changes in total executive compensation between the annual reports. All compensation reports must indicate what percent of compensation comes directly from the State or Federal allocations to the Grantee.

**40. Execution in Counterparts and Authority to Sign.**

This Agreement, any amendments, and/or change orders related to the Agreement, may be executed in counterparts, each of which shall be an original and all of which shall constitute the same instrument. In accordance with the Electronic Signature Act of 1996, electronic signatures, including facsimile transmissions, may be used and shall have the same force and effect as a written signature. Each person signing this Agreement warrants that he or she is duly authorized to do so and to bind the respective party to the Agreement.

STATE OF FLORIDA  
DEPARTMENT OF ENVIRONMENTAL PROTECTION  
Special Terms and Conditions  
AGREEMENT NO. NS104

ATTACHMENT 2

These Special Terms and Conditions shall be read together with general terms outlined in the Standard Terms and Conditions, Attachment 1. Where in conflict, these more specific terms shall apply.

**1. Scope of Work.**

The Project funded under this Agreement is Shingle Creek Pond 6459: BMP Treatment Train. The Project is defined in more detail in Attachment 3, Grant Work Plan.

**2. Duration.**

- a. Reimbursement Period. The reimbursement period for this Agreement is the same as the terms of the Agreement.
- b. Extensions. There are extensions available for this Project.
- c. Service Periods. Additional service periods are not authorized under this Agreement.

**3. Payment Provisions.**

- a. Compensation. This is a cost reimbursement Agreement. The Grantee shall be compensated under this Agreement as described in Attachment 3.
- b. Invoicing. Invoicing will occur as indicated in Attachment 3.
- c. Advance Pay. Advance Pay is not authorized under this Agreement.

**4. Cost Eligible for Reimbursement or Matching Requirements.**

Reimbursement for costs or availability for costs to meet matching requirements shall be limited to the following budget categories, as defined in the Reference Guide for State Expenditures, as indicated:

<u>Reimbursement</u>	<u>Match</u>	<u>Category</u>
<input type="checkbox"/>	<input type="checkbox"/>	Salaries/Wages
		Overhead/Indirect/General and Administrative Costs:
<input type="checkbox"/>	<input type="checkbox"/>	a. Fringe Benefits, N/A.
<input type="checkbox"/>	<input type="checkbox"/>	b. Indirect Costs, N/A.
<input checked="" type="checkbox"/>	<input type="checkbox"/>	Contractual (Subcontractors)
<input type="checkbox"/>	<input type="checkbox"/>	Travel, in accordance with Section 112, F.S.
<input type="checkbox"/>	<input type="checkbox"/>	Equipment
<input type="checkbox"/>	<input type="checkbox"/>	Rental/Lease of Equipment
<input type="checkbox"/>	<input type="checkbox"/>	Miscellaneous/Other Expenses
<input type="checkbox"/>	<input type="checkbox"/>	Land Acquisition

**5. Equipment Purchase.**

No Equipment purchases shall be funded under this Agreement.

**6. Land Acquisition.**

There will be no Land Acquisitions funded under this Agreement.

**7. Match Requirements**

There is no match required on the part of the Grantee under this Agreement.

**8. Insurance Requirements**



**Required Coverage.** At all times during the Agreement the Grantee, at its sole expense, shall maintain insurance coverage of such types and with such terms and limits described below. The limits of coverage under each policy maintained by the Grantee shall not be interpreted as limiting the Grantee's liability and obligations under the Agreement. All insurance policies shall be through insurers licensed and authorized to issue policies in Florida, or alternatively, Grantee may provide coverage through a self-insurance program established and operating under the laws of Florida. Additional insurance requirements for this Agreement may be required elsewhere in this Agreement, however the minimum insurance requirements applicable to this Agreement are:

a. Commercial General Liability Insurance.

The Grantee shall provide adequate commercial general liability insurance coverage and hold such liability insurance at all times during the Agreement. The Department, its employees, and officers shall be named as an additional insured on any general liability policies. The minimum limits shall be \$250,000 for each occurrence and \$500,000 policy aggregate.

b. Commercial Automobile Insurance.

If the Grantee's duties include the use of a commercial vehicle, the Grantee shall maintain automobile liability, bodily injury, and property damage coverage. Insuring clauses for both bodily injury and property damage shall provide coverage on an occurrence basis. The Department, its employees, and officers shall be named as an additional insured on any automobile insurance policy. The minimum limits shall be as follows:

\$200,000/300,000	Automobile Liability for Company-Owned Vehicles, if applicable
\$200,000/300,000	Hired and Non-owned Automobile Liability Coverage

c. Workers' Compensation and Employer's Liability Coverage.

The Grantee shall provide workers' compensation, in accordance with Chapter 440, F.S. and employer liability coverage with minimum limits of \$100,000 per accident, \$100,000 per person, and \$500,000 policy aggregate. Such policies shall cover all employees engaged in any work under the Grant.

d. Other Insurance. None.

**9. Quality Assurance Requirements.**

There are no special Quality Assurance requirements under this Agreement.

**10. Retainage.**

Retainage is permitted under this Agreement. Retainage may be up to a maximum of 10% of the total amount of the Agreement.

**11. Subcontracting.**

The Grantee may subcontract work under this Agreement without the prior written consent of the Department's Grant Manager except for certain fixed-price subcontracts pursuant to this Agreement, which require prior approval. The Grantee shall submit a copy of the executed subcontract to the Department prior to submitting any invoices for subcontracted work. Regardless of any subcontract, the Grantee is ultimately responsible for all work to be performed under this Agreement.

**12. State-owned Land.**

The work will not be performed on State-owned land.

**13. Office of Policy and Budget Reporting.**

There are no special Office of Policy and Budget reporting requirements for this Agreement.

**14. Common Carrier.**

- a. Applicable to contracts with a common carrier – firm/person/corporation that as a regular business transports people or commodities from place to place. If applicable, Contractor must also fill out and return PUR 1808 before contract execution] If Contractor is a common carrier pursuant to section 908.111(1)(a), Florida Statutes, the Department will terminate this contract immediately if Contractor is found to be in violation of the law or the attestation in PUR 1808.
- b. Applicable to solicitations for a common carrier – Before contract execution, the winning Contractor(s) must fill out and return PUR 1808, and attest that it is not willfully providing any service in furtherance of transporting a person into this state knowing that the person unlawfully present in the United States

according to the terms of the federal Immigration and Nationality Act, 8 U.S.C. ss. 1101 et seq. The Department will terminate a contract immediately if Contractor is found to be in violation of the law or the attestation in PUR 1808

**15. Additional Terms.**

None.

*Any terms added here must be approved by the Office of General Counsel.*

### ATTACHMENT 3 GRANT WORK PLAN

**PROJECT TITLE:** Shingle Creek Pond 6459: BMP Treatment Train

**PROJECT LOCATION:** The Project will be located in the City of Orlando within Orange County; Lat/Long (28.48086, -81.42528). See Figure 1 for a location map.

**PROJECT BACKGROUND:** Shingle Creek (WBID 3169A) is impaired for nutrients and falls within the Lake Okeechobee Basin Management Action Plan (BMAP) area. The Orange County (Grantee) project will modify an existing stormwater pond into a treatment train by expanding the pond volume through additional excavation and piping, which will also increase the residence time within the pond; pumping canal water for treatment through the pond; and providing biosorption activated media filtration at the outflow prior to discharge from the pond. This project is expected to remove significant amounts of total nitrogen and total phosphorus, reducing the load to Shingle Creek and ultimately to Lake Okeechobee.

**PROJECT DESCRIPTION:** The Grantee will construct a stormwater treatment train through expansion of an existing pond, installation of a pump station, and construction of a side bank filtration system with bioactive media at the outfall.

The DEP Grant Funds associated with this Agreement were awarded based on local contributions pledged towards the total project costs: \$642,400 from Orange County Government. A summary of the local contributions will be required in the Final Report, and financial supporting documentation of locally pledged contributions shall be provided upon request.

**TASKS:** All documentation should be submitted electronically unless otherwise indicated.

#### **Task 1: Construction**

**Deliverables:** The Grantee will construct the Shingle Creek Pond 6459: BMP Treatment Train, in accordance with the construction contract documents.

**Documentation:** The Grantee will submit 1) a copy of the final design; 2) a signed acceptance of the completed work to date, as provided in the Grantee's Certification of Payment Request; and 3) a signed Engineer's Certification of Payment Request.

**Performance Standard:** The Department's Grant Manager will review the documentation to verify that the deliverables have been completed as described above. Upon review and written acceptance by the Department's Grant Manager, the Grantee may proceed with payment request submittal.

**Payment Request Schedule:** The Grantee may submit a payment request for cost reimbursement no more frequently than monthly.

#### **Task 2: Final Report**

**Deliverables:** The Grantee will prepare a Final Report summarizing the results of the project, including all tasks in the Grant Work Plan. The Final Report must include at a minimum:

- Project location and background, project description and timeline, grant award amount and anticipated benefits.

- Financial summary of actual costs versus the budget, along with any changes required to the budget. Include any match or locally pledged contributions provided, along with other related project work performed outside of this Agreement to identify the overall project cost.
- Discussion of project schedule versus actual completion, including changes required to the schedule, unexpected site conditions and adjustments, significant unexpected delays and corrections, and/or other significant deviations from the original project plan.
- Summary of activities completed as well as those not completed and why, as well as a brief summary of any additional phases yet to be completed.
- Dated color photographs of work performed (representative of the entire project), appropriate figures (site location, site plan(s), etc.), appropriate tables summarizing data/information relevant to Grant Work Plan tasks, and appropriate attachments relevant to the project.
- Projects associated with and listed in a Water Quality Restoration Plan are expected to be maintained for the life of the project to retain reduction credits under the Plan(s) unless noted otherwise. If possible, identify the expected lifetime of the Best Management Practices (BMPs) and if there is a detailed plan to operate and maintain the system through this period. If possible, describe the amount of time, cost, and work that will be required to operate and maintain the system.

**Documentation:** The Grantee will submit: 1) a copy of the draft Final Report in Word format; and 2) a copy of the Department-approved Final Report in Word or PDF format.

**Performance Standard:** The Department’s Grant Manager will review the documentation to verify that the deliverables have been completed as described above. Upon review and written acceptance by the Department’s Grant Manager, the Grantee may proceed with payment request submittal.

**Payment Request Schedule:** The Grantee may submit a payment request for cost reimbursement or match documentation following the conclusion of the task.

**PROJECT TIMELINE & BUDGET DETAIL:**

The tasks must be completed by, and all documentation received by, the corresponding task end date. Cost reimbursable grant funding must not exceed the budget amounts as indicated below.

Task No.	Task Title	Budget Category	Grant Amount	Task Start Date	Task End Date
1	Construction	Contractual Services	\$500,000	Upon Execution	03/31/2026
2	Draft Final Report	No-Cost Deliverable	\$0	Upon Execution	07/31/2026
	Final Report				08/31/2026
Total:			\$500,000		

REMAINDER OF PAGE INTENTIONALLY LEFT BLANK

Figure 1: Location Map



REMAINDER OF PAGE INTENTIONALLY LEFT BLANK



STATE OF FLORIDA  
DEPARTMENT OF ENVIRONMENTAL PROTECTION  
Public Records Requirements

Attachment 4

**1. Public Records.**

- a. If the Agreement exceeds \$35,000.00, and if Grantee is acting on behalf of Department in its performance of services under the Agreement, Grantee must allow public access to all documents, papers, letters, or other material, regardless of the physical form, characteristics, or means of transmission, made or received by Grantee in conjunction with the Agreement (Public Records), unless the Public Records are exempt from section 24(a) of Article I of the Florida Constitution or section 119.07(1), F.S.
- b. The Department may unilaterally terminate the Agreement if Grantee refuses to allow public access to Public Records as required by law.

**2. Additional Public Records Duties of Section 119.0701, F.S., If Applicable.**

For the purposes of this paragraph, the term “contract” means the “Agreement.” If Grantee is a “contractor” as defined in section 119.0701(1)(a), F.S., the following provisions apply and the contractor shall:

- a. Keep and maintain Public Records required by Department to perform the service.
- b. Upon request, provide Department with a copy of requested Public Records or allow the Public Records to be inspected or copied within a reasonable time at a cost that does not exceed the cost provided in Chapter 119, F.S., or as otherwise provided by law.
- c. A contractor who fails to provide the Public Records to Department within a reasonable time may be subject to penalties under section 119.10, F.S.
- d. Ensure that Public Records that are exempt or confidential and exempt from Public Records disclosure requirements are not disclosed except as authorized by law for the duration of the contract term and following completion of the contract if the contractor does not transfer the Public Records to Department.
- e. Upon completion of the contract, transfer, at no cost, to Department all Public Records in possession of the contractor or keep and maintain Public Records required by Department to perform the service. If the contractor transfers all Public Records to Department upon completion of the contract, the contractor shall destroy any duplicate Public Records that are exempt or confidential and exempt from Public Records disclosure requirements. If the contractor keeps and maintains Public Records upon completion of the contract, the contractor shall meet all applicable requirements for retaining Public Records. All Public Records stored electronically must be provided to Department, upon request from Department’s custodian of Public Records, in a format specified by Department as compatible with the information technology systems of Department. These formatting requirements are satisfied by using the data formats as authorized in the contract or Microsoft Word, Outlook, Adobe, or Excel, and any software formats the contractor is authorized to access.

- f. **IF THE CONTRACTOR HAS QUESTIONS REGARDING THE APPLICATION OF CHAPTER 119, F.S., TO THE CONTRACTOR’S DUTY TO PROVIDE PUBLIC RECORDS RELATING TO THE CONTRACT, CONTACT THE DEPARTMENT’S CUSTODIAN OF PUBLIC RECORDS AT:**

**Telephone:** (850) 245-2118  
**Email:** [public.services@floridadep.gov](mailto:public.services@floridadep.gov)  
**Mailing Address:** Department of Environmental Protection  
**ATTN: Office of Ombudsman and Public Services**  
**Public Records Request**  
**3900 Commonwealth Boulevard, MS 49**  
**Tallahassee, Florida 32399**



**STATE OF FLORIDA**  
**DEPARTMENT OF ENVIRONMENTAL PROTECTION**  
**Special Audit Requirements**  
**(State and Federal Financial Assistance)**

**Attachment 5**

The administration of resources awarded by the Department of Environmental Protection (*which may be referred to as the "Department", "DEP", "FDEP" or "Grantor", or other name in the agreement*) to the recipient (*which may be referred to as the "Recipient", "Grantee" or other name in the agreement*) may be subject to audits and/or monitoring by the Department of Environmental Protection, as described in this attachment.

**MONITORING**

In addition to reviews of audits conducted in accordance with 2 CFR Part 200, Subpart F-Audit Requirements, and Section 215.97, F.S., as revised (see "AUDITS" below), monitoring procedures may include, but not be limited to, on-site visits by DEP Department staff, limited scope audits as defined by 2 CFR 200.425, or other procedures. By entering into this Agreement, the recipient agrees to comply and cooperate with any monitoring procedures/processes deemed appropriate by the Department of Environmental Protection. In the event the Department of Environmental Protection determines that a limited scope audit of the recipient is appropriate, the recipient agrees to comply with any additional instructions provided by the Department to the recipient regarding such audit. The recipient further agrees to comply and cooperate with any inspections, reviews, investigations, or audits deemed necessary by the Chief Financial Officer (CFO) or Auditor General.

**AUDITS**

**PART I: FEDERALLY FUNDED**

This part is applicable if the recipient is a State or local government or a non-profit organization as defined in 2 CFR §200.330

1. A recipient that expends \$750,000 or more in Federal awards in its fiscal year, must have a single or program-specific audit conducted in accordance with the provisions of 2 CFR Part 200, Subpart F. EXHIBIT 1 to this Attachment indicates Federal funds awarded through the Department of Environmental Protection by this Agreement. In determining the federal awards expended in its fiscal year, the recipient shall consider all sources of federal awards, including federal resources received from the Department of Environmental Protection. The determination of amounts of federal awards expended should be in accordance with the guidelines established in 2 CFR 200.502-503. An audit of the recipient conducted by the Auditor General in accordance with the provisions of 2 CFR Part 200.514 will meet the requirements of this part.
2. For the audit requirements addressed in Part I, paragraph 1, the recipient shall fulfill the requirements relative to auditee responsibilities as provided in 2 CFR 200.508-512.
3. A recipient that expends less than \$750,000 in federal awards in its fiscal year is not required to have an audit conducted in accordance with the provisions of 2 CFR Part 200, Subpart F-Audit Requirements. If the recipient expends less than \$750,000 in federal awards in its fiscal year and elects to have an audit conducted in accordance with the provisions of 2 CFR 200, Subpart F-Audit Requirements, the cost of the audit must be paid from non-federal resources (i.e., the cost of such an audit must be paid from recipient resources obtained from other federal entities).
4. The recipient may access information regarding the Catalog of Federal Domestic Assistance (CFDA) via the internet at <https://sam.gov/content/assistance-listings>.

## PART II: STATE FUNDED

This part is applicable if the recipient is a nonstate entity as defined by Section 215.97(2), Florida Statutes.

1. In the event that the recipient expends a total amount of state financial assistance equal to or in excess of \$750,000 in any fiscal year of such recipient (for fiscal years ending June 30, 2017, and thereafter), the recipient must have a State single or project-specific audit for such fiscal year in accordance with Section 215.97, F.S.; Rule Chapter 69I-5, F.A.C., State Financial Assistance; and Chapters 10.550 (local governmental entities) or 10.650 (nonprofit and for-profit organizations), Rules of the Auditor General. EXHIBIT I to this form lists the state financial assistance awarded through the Department of Environmental Protection by this agreement. In determining the state financial assistance expended in its fiscal year, the recipient shall consider all sources of state financial assistance, including state financial assistance received from the Department of Environmental Protection, other state agencies, and other nonstate entities. State financial assistance does not include federal direct or pass-through awards and resources received by a nonstate entity for Federal program matching requirements.
2. In connection with the audit requirements addressed in Part II, paragraph 1; the recipient shall ensure that the audit complies with the requirements of Section 215.97(8), Florida Statutes. This includes submission of a financial reporting package as defined by Section 215.97(2), Florida Statutes, and Chapters 10.550 (local governmental entities) or 10.650 (nonprofit and for-profit organizations), Rules of the Auditor General.
3. If the recipient expends less than \$750,000 in state financial assistance in its fiscal year (for fiscal year ending June 30, 2017, and thereafter), an audit conducted in accordance with the provisions of Section 215.97, Florida Statutes, is not required. In the event that the recipient expends less than \$750,000 in state financial assistance in its fiscal year, and elects to have an audit conducted in accordance with the provisions of Section 215.97, Florida Statutes, the cost of the audit must be paid from the non-state entity's resources (i.e., the cost of such an audit must be paid from the recipient's resources obtained from other than State entities).
4. For information regarding the Florida Catalog of State Financial Assistance (CSFA), a recipient should access the Florida Single Audit Act website located at <https://apps.fldfs.com/fsaa> for assistance. In addition to the above websites, the following websites may be accessed for information: Legislature's Website at <http://www.leg.state.fl.us/Welcome/index.cfm>, State of Florida's website at <http://www.myflorida.com/>, Department of Financial Services' Website at <http://www.fldfs.com/> and the Auditor General's Website at <http://www.myflorida.com/audgen/>.

## PART III: OTHER AUDIT REQUIREMENTS

*(NOTE: This part would be used to specify any additional audit requirements imposed by the State awarding entity that are solely a matter of that State awarding entity's policy (i.e., the audit is not required by Federal or State laws and is not in conflict with other Federal or State audit requirements). Pursuant to Section 215.97(8), Florida Statutes, State agencies may conduct or arrange for audits of State financial assistance that are in addition to audits conducted in accordance with Section 215.97, Florida Statutes. In such an event, the State awarding agency must arrange for funding the full cost of such additional audits.)*

## PART IV: REPORT SUBMISSION

1. Copies of reporting packages for audits conducted in accordance with 2 CFR Part 200, Subpart F-Audit Requirements, and required by PART I of this form shall be submitted, when required by 2 CFR 200.512, by or on behalf of the recipient directly to the Federal Audit Clearinghouse (FAC) as provided in 2 CFR 200.36 and 200.512
  - A. The Federal Audit Clearinghouse designated in 2 CFR §200.501(a) (the number of copies required by 2 CFR §200.501(a) should be submitted to the Federal Audit Clearinghouse), at the following address:

By Mail:

Federal Audit Clearinghouse  
Bureau of the Census  
1201 East 10th Street  
Jeffersonville, IN 47132

Submissions of the Single Audit reporting package for fiscal periods ending on or after January 1, 2008, must be submitted using the Federal Clearinghouse's Internet Data Entry System which can be found at <http://harvester.census.gov/facweb/>

2. Copies of financial reporting packages required by PART II of this Attachment shall be submitted by or on behalf of the recipient directly to each of the following:

A. The Department of Environmental Protection at one of the following addresses:

By Mail:

**Audit Director**  
Florida Department of Environmental Protection  
Office of Inspector General, MS 40  
3900 Commonwealth Boulevard  
Tallahassee, Florida 32399-3000

Electronically:

[FDEPSingleAudit@dep.state.fl.us](mailto:FDEPSingleAudit@dep.state.fl.us)

B. The Auditor General's Office at the following address:

Auditor General  
Local Government Audits/342  
Claude Pepper Building, Room 401  
111 West Madison Street  
Tallahassee, Florida 32399-1450

The Auditor General's website (<http://flauditor.gov/>) provides instructions for filing an electronic copy of a financial reporting package.

3. Copies of reports or management letters required by PART III of this Attachment shall be submitted by or on behalf of the recipient directly to the Department of Environmental Protection at one of the following addresses:

By Mail:

**Audit Director**  
Florida Department of Environmental Protection  
Office of Inspector General, MS 40  
3900 Commonwealth Boulevard  
Tallahassee, Florida 32399-3000

Electronically:

[FDEPSingleAudit@dep.state.fl.us](mailto:FDEPSingleAudit@dep.state.fl.us)

4. Any reports, management letters, or other information required to be submitted to the Department of Environmental Protection pursuant to this Agreement shall be submitted timely in accordance with 2 CFR 200.512, section 215.97, F.S., and Chapters 10.550 (local governmental entities) or 10.650 (nonprofit and for-profit organizations), Rules of the Auditor General, as applicable.

5. Recipients, when submitting financial reporting packages to the Department of Environmental Protection for audits done in accordance with 2 CFR 200, Subpart F-Audit Requirements, or Chapters 10.550 (local governmental entities) and 10.650 (non and for-profit organizations), Rules of the Auditor General, should indicate the date and the reporting package was delivered to the recipient correspondence accompanying the reporting package.

#### **PART V: RECORD RETENTION**

The recipient shall retain sufficient records demonstrating its compliance with the terms of the award and this Agreement for a period of **five (5)** years from the date the audit report is issued, and shall allow the Department of Environmental Protection, or its designee, Chief Financial Officer, or Auditor General access to such records upon request. The recipient shall ensure that audit working papers are made available to the Department of Environmental Protection, or its designee, Chief Financial Officer, or Auditor General upon request for a period of **three (3)** years from the date the audit report is issued, unless extended in writing by the Department of Environmental Protection.

**EXHIBIT – 1**

FUNDS AWARDED TO THE RECIPIENT PURSUANT TO THIS AGREEMENT CONSIST OF THE FOLLOWING:

*Note: If the resources awarded to the recipient represent more than one federal program, provide the same information shown below for each federal program and show total federal resources awarded*

<b>Federal Resources Awarded to the Recipient Pursuant to this Agreement Consist of the Following:</b>					
<b>Federal Program A</b>	Federal Agency	CFDA Number	CFDA Title	Funding Amount	State Appropriation Category
				\$	
<b>Federal Program B</b>	Federal Agency	CFDA Number	CFDA Title	Funding Amount	State Appropriation Category
				\$	

*Note: Of the resources awarded to the recipient represent more than one federal program, list applicable compliance requirements for each federal program in the same manner as shown below:*

<b>Federal Program A</b>	First Compliance requirement: i.e.: (what services of purposes resources must be used for)	
	Second Compliance requirement: i.e.: (eligibility requirement for recipients of the resources)	
	Etc.	
	Etc.	
<b>Federal Program B</b>	First Compliance requirement: i.e.: (what services of purposes resources must be used for)	
	Second Compliance requirement: i.e.: (eligibility requirement for recipients of the resources)	
	Etc.	
	Etc.	

Note: If the resources awarded to the recipient for matching represent more than one federal program, provide the same information shown below for each federal program and show total state resources awarded for matching.

State Resources Awarded to the Recipient Pursuant to this Agreement Consist of the Following Matching Resources for Federal Programs:					
Federal Program A	Federal Agency	CFDA	CFDA Title	Funding Amount	State Appropriation Category
Federal Program B	Federal Agency	CFDA	CFDA Title	Funding Amount	State Appropriation Category

Note: If the resources awarded to the recipient represent more than one state project, provide the same information shown below for each state project and show total state financial assistance awarded that is subject to section 215.97, F.S.

State Resources Awarded to the Recipient Pursuant to this Agreement Consist of the Following Resources Subject to Section 215.97, F.S.:						
State Program A	State Awarding Agency	State Fiscal Year <sup>1</sup>	CSFA Number	CSFA Title or Funding Source Description	Funding Amount	State Appropriation Category
Original Agreement	Florida Department of Environmental Protection	2022-2023	37.039	Statewide Water Quality Restoration Projects	\$500,000	140076
State Program B	State Awarding Agency	State Fiscal Year <sup>2</sup>	CSFA Number	CSFA Title or Funding Source Description	Funding Amount	State Appropriation Category

<b>Total Award</b>	<b>\$500,000</b>
--------------------	------------------

Note: List applicable compliance requirement in the same manner as illustrated above for federal resources. For matching resources provided by the Department for DEP for federal programs, the requirements might be similar to the requirements for the applicable federal programs. Also, to the extent that different requirements pertain to different amount for the non-federal resources, there may be more than one grouping (i.e. 1, 2, 3, etc.) listed under this category.

For each program identified above, the recipient shall comply with the program requirements described in the Catalog of Federal Domestic Assistance (CFDA) [<https://sam.gov/content/assistance-listings>] and/or the Florida Catalog of State Financial Assistance (CSFA) [<https://apps.fldfs.com/fsaa/searchCatalog.aspx>], and State Projects Compliance Supplement (Part Four: State Projects Compliance Supplement [[https://apps.fldfs.com/fsaa/state\\_project\\_compliance.aspx](https://apps.fldfs.com/fsaa/state_project_compliance.aspx)]). The services/purposes for which the funds are to be used are included in the Agreement's Grant Work Plan. Any match required by the Recipient is clearly indicated in the Agreement.

<sup>1</sup> Subject to change by Change Order.

<sup>2</sup> Subject to change by Change Order.



**STATE OF FLORIDA  
DEPARTMENT OF ENVIRONMENTAL PROTECTION**

**Exhibit A  
Progress Report Form**

<b>DEP Agreement No.:</b>	NS104
<b>Project Title:</b>	Shingle Creek Pond 6459: BMP Treatment Train
<b>Grantee Name:</b>	Orange County, a political subdivision of the State of Florida
<b>Grantee's Grant Manager:</b>	Emily Lawson, P.E.
<b>Reporting Period:</b>	Select Quarter - Select Year

**Provide the following information for all tasks identified in the Grant Work Plan:**

Summarize the eligible grant [and required match, if applicable] work completed within each task for the reporting period, provide an update on the estimated completion date for each task, and identify any anticipated delays or problems encountered. Use the format provided below and use as many pages as necessary to cover all tasks. Each quarterly progress report is due no later than twenty (20) days following the completion of the quarterly reporting period.

**Task 1: Construction**

- Progress for this reporting period:
- Identify delays or problems encountered:

**Task 2: Final Report**

- Progress for this reporting period:
- Identify delays or problems encountered:

**Completion Status for Tasks:**

Indicate the completion status for the following tasks, if included in the Grant Work Plan. For construction, the estimated completion percentage should represent the work being funded under this Agreement.

**Construction (Estimated):** \_\_\_\_\_ %

**Local Contributions:**

For grant agreements with local contributions, a summary of the local contributions will be required in the Final Quarterly Progress Report. Provide a brief summary below of the local contribution amounts that have been used toward the project.

- Summary of local contributions:

This report is submitted in accordance with the reporting requirements of the above DEP Agreement number and accurately reflects the activities associated with the project.

---

Signature of Grantee's Grant Manager  
*(Original Ink or Digital Timestamp)*

---

Date

**STATE OF FLORIDA  
DEPARTMENT OF ENVIRONMENTAL PROTECTION**

**Exhibit C  
Payment Request Summary Form**

The **Payment Request Summary Form** for this grant can be found on our website at this link:

<https://floridadep.gov/wra/wra/documents/payment-request-summary-form>

Please use the most current form found on the website, linked above, for each payment request.