

*Board of County Commissioners*

**After-the-Fact Shoreline Alteration/Dredge  
and Fill Permit Application**

**SADF-22-02-004**

**Applicant: Shaun Murray**

**June 21, 2022**



# Location Map

12310 Kirby Smith Road, Orlando, FL

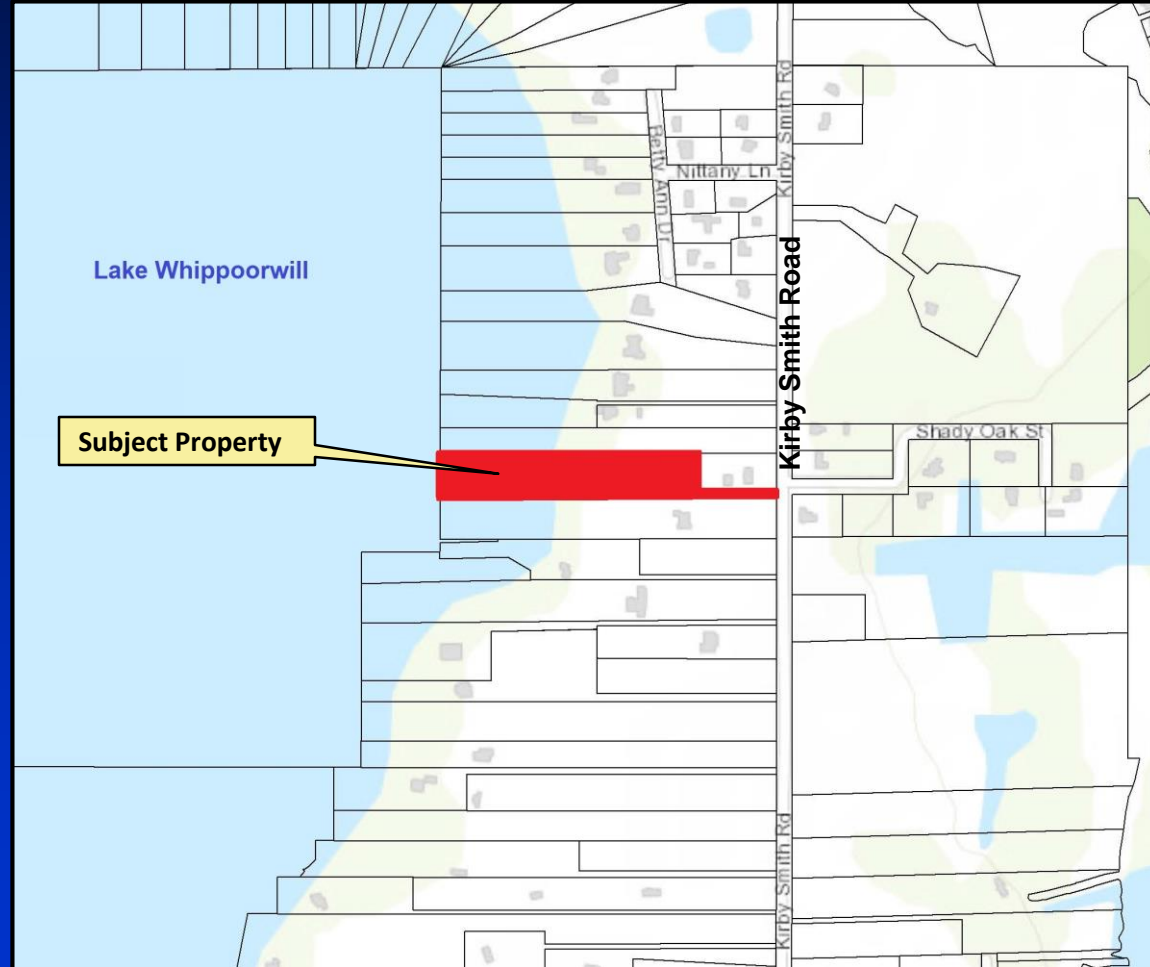

Parcel ID No. 20-24-31-0000-00-036



# Aerial Photo

12310 Kirby Smith Road, Orlando, FL



Parcel ID No. 20-24-31-0000-00-036



# Existing Conditions





# Site Plan

**MURRAY RIPRAP SITE PLAN**  
12310 KIRBY SMITH ROAD  
ORLANDO, FL 32832

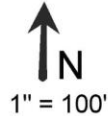

**Unroe Engineering, Inc**  
Civil Engineering/Planning/Scientific Evaluations  
PO Box 690942, Orlando, Florida 32869  
Ph (407) 299-0650 <> Darcy@UnroeEngineering.com

A COMBINATION OF DUCK POTATO, PICKERELWEED, CANNA FLACCIDA & BLUE IRIS WILL BE PLANTED ON 2' CENTERS IN THE AREAS NOTED TO ACHIEVE 80% DENSITY

This item has been electronically signed and sealed by Darcy Unroe, PE 60929 on the date indicated using a Digital Signature  
Printed copies of this document are not considered signed and sealed and the signature must be verified on any electronic copy.

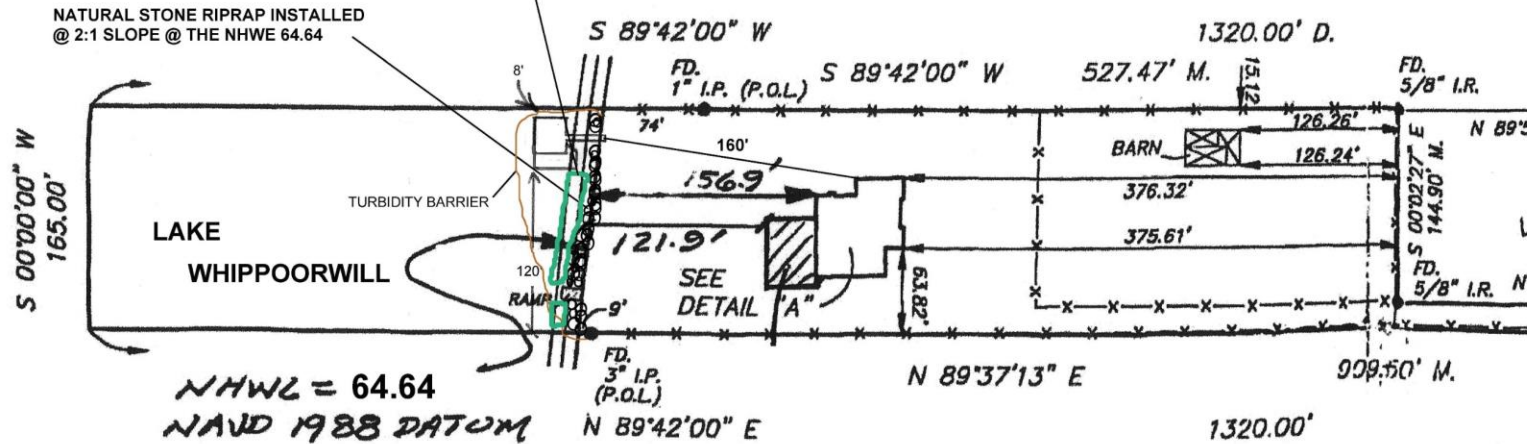

*THIS IS TO CERTIFY THE LOCATION OF THE NHWL WAS LOCATED ON 10-6-2014 USING ORANGE COUNTY BENCH MARK C-1134031 NAVD 1988 DATUM TO DETERMINE THE NHWL IN RELATION TO THE EXISTING BUILDING AND PROPOSED RESIDENCE'S POOL*

ENGINEER'S SEAL AS TO SITE PLAN ONLY



Darcy Unroe  
c=US, st=Florida,  
l=Orlando, o=Unroe  
Engineering, Inc., cn=Darcy  
Unroe,  
email=Darcy@unroeengine  
ering.com  
2022.03.24 13:05:20 -04'00'



# Site Plan



**Unroe Engineering, Inc**  
**Civil Engineering/Planning/Scientific Evaluations**  
 PO Box 690942, Orlando, Florida 32869  
 Ph (407) 299-0650 <> Darcy@UnroeEngineering.com



Darcy Unroe  
 c=US, st=Florida,  
 l=Orlando,  
 o=Unroe  
 Engineering, Inc.,  
 cn=Darcy Unroe,  
 email=Darcy@unroe  
 engineering.com  
 2022.03.24  
 13:06:00 -04'00'

**3' X 150' NATURAL STONE >12" DIAMETER RIP-RAP  
 REVETMENT INSTALLED @ THE NHWE @ A 2:1 SLOPE**

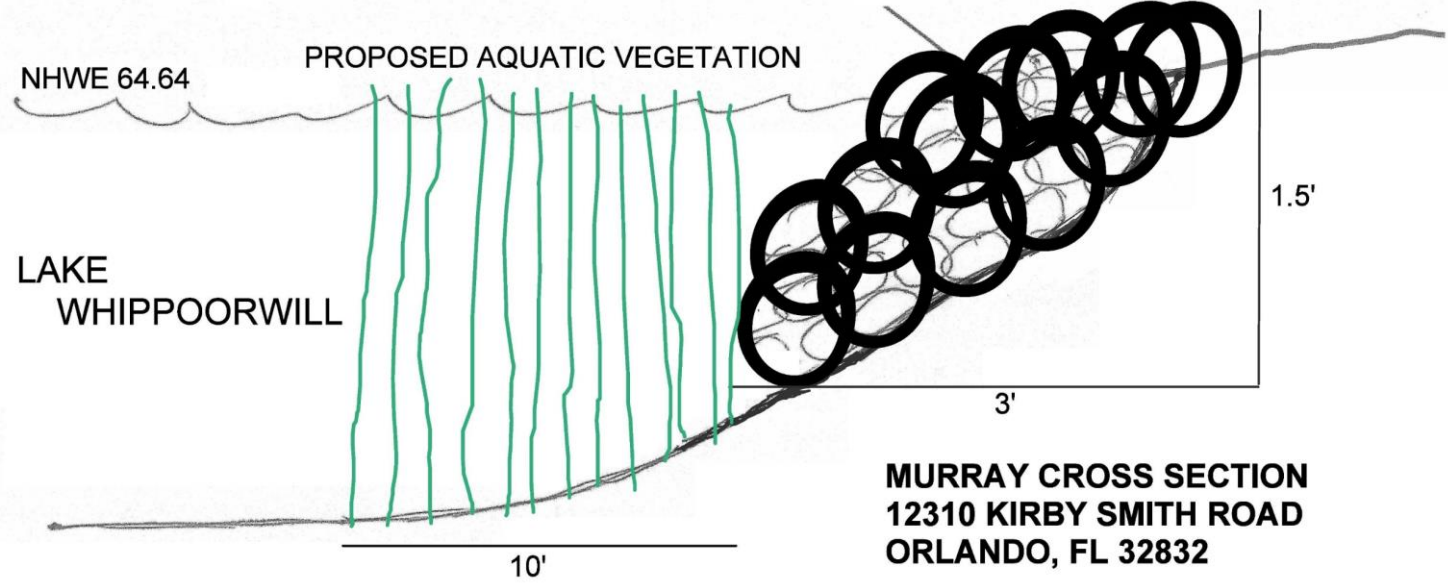

**MURRAY CROSS SECTION  
 12310 KIRBY SMITH ROAD  
 ORLANDO, FL 32832**

This item has been electronically signed and sealed by Darcy Unroe, PE 60929 on the date indicated using a Digital Signature. Printed copies of this document are not considered signed and sealed and the signature must be verified on any electronic copy.



## Considerations

- **Project reviewed in accordance with Chapter 15, Article VI and the review criteria and conditions of issuance therein.**
- **Notification of the public hearing was sent to property owners within 500 feet of the project site. No objections were received.**



## Finding

- Pursuant to Orange County Code, Chapter 15, Article VI, EPD staff has evaluated the proposed SADF permit application and required documents and has made a finding that the request is consistent with Section 15-218.





## Action Requested

- **Acceptance of the findings and recommendation of the Environmental Protection Division staff and approval of Shoreline Alteration/Dredge and Fill Permit SADF-22-02-004 for Shaun Murray, subject to the conditions listed in the staff report. District 4**



# Existing Conditions

