



Interoffice Memorandum

Received: May 4, 2022 @ 1:03pm
Publish: June 5
Deadline: May 31

May 3, 2022

To: Katie Smith, Manager
Comptroller Clerk's Office

Through: Cheryl Gillespie, Agenda Development Supervisor
Agenda Development

From: David D. Jones, P.E., CEP, Manager
Environmental Protection Division
(407) 836-1406

A handwritten signature in blue ink, appearing to be "DJ", located to the right of the "From:" field.

Staff Person: Elizabeth R. Johnson, CEP, Assistant Manager
Environmental Protection Division
(407) 836-1511

Subject: Request for Public Hearing on June 21, 2022, at 2:00 p.m., for an After-the-Fact Shoreline Alteration/Dredge and Fill Permit Application (SADF-22-02-004) to keep 150 feet of riprap along Lake Whippoorwill at 12310 Kirby Smith Road, Orlando, FL 32832. Parcel ID No. 20-24-31-0000-00-036; District 4

Applicant: Shaun Murray

Type of Hearing: Shoreline Alteration/Dredge and Fill Permit Application

Hearing required by
Florida Statute # or Code: Chapter 15, Article VI, Pumping and Dredging Control

Advertising requirements: Publish once in a newspaper of general circulation in Orange County at least (7) seven days prior to public hearing.

Advertising timeframes: At least (7) seven days prior to public hearing.

Abutters to be notified: The applicant and the property owners within 500 feet of the project area will be notified at least (7) seven days prior to public hearing by the Environmental Protection Division (EPD).

Page 2

May 3, 2022

Request for Public Hearing – After-the-Fact Shoreline Alteration/Dredge and Fill Permit Application for Shaun Murray (SADF-22-02-004)

Estimated time required

For public hearing: 2 minutes

Municipality or other
Public Agency to be
notified:

Florida Department of Environmental Protection,
DEP_CD@dep.state.fl.us

Hearing Controversial: No

District #: 4

Materials being submitted as backup for public hearing request:

1. Site Plan
2. Location Map

Special Instructions to Clerk:

1. Once the Board of County Commissioners makes a decision on the Shoreline Alteration/Dredge and Fill Permit Application, please submit the decision letter to Liz Johnson with EPD. EPD will issue the decision to the applicant.

Advertising Language:

1. Applicant, Shaun Murray, is requesting an After-the-Fact Shoreline Alteration/Dredge and Fill Permit (SADF-22-02-004) to keep 150 feet of riprap along Lake Whippoorwill at 12310 Kirby Smith Road, Orlando, FL 32832. Parcel ID No. 20-24-31-0000-00-036; District 4 (property legal description on file at EPD).

HD/NT/TMH/ERJ/DJ/jk

Attachments

Shoreline Alteration/Dredge and Fill Permit Request



**Shoreline Alteration/Dredge and Fill
Permit Request
SADF-22-02-004
District #4**

**Applicant: Shaun Murray
Address: 12310 Kirby Smith Road
Parcel ID No.: 20-24-31-0000-00-036**

Project Site 

Property Location 

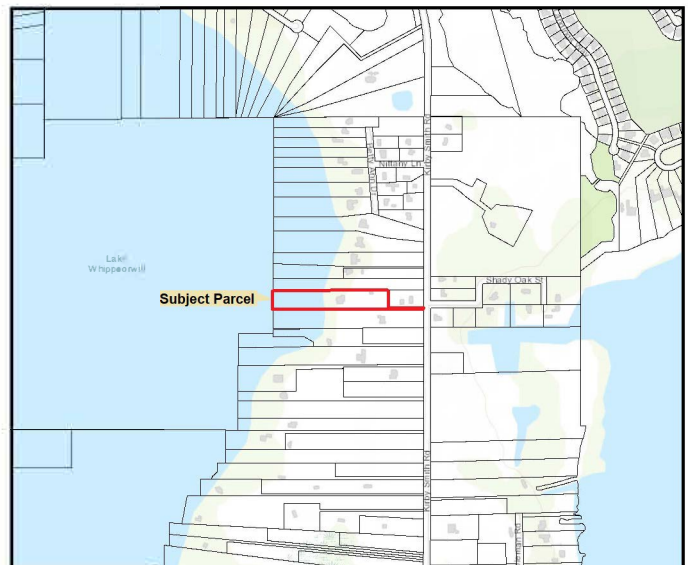

MURRAY RIPRAP SITE PLAN
12310 KIRBY SMITH ROAD
ORLANDO, FL 32832

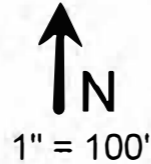

received
3/24/2022



Unroe Engineering, Inc
Civil Engineering/Planning/Scientific Evaluations
PO Box 690942, Orlando, Florida 32869
Ph (407) 299-0650 <> Darcy@UnroeEngineering.com

A COMBINATION OF DUCK POTATO, PICKERELWEED, CANNA FLACCIDA & BLUE IRIS WILL BE PLANTED ON 2' CENTERS IN THE AREAS NOTED TO ACHIEVE 80% DENSITY

This item has been electronically signed and sealed by Darcy Unroe, PE 60929 on the date indicated using a Digital Signature
 Printed copies of this document are not considered signed and sealed and the signature must be verified on any electronic copy.

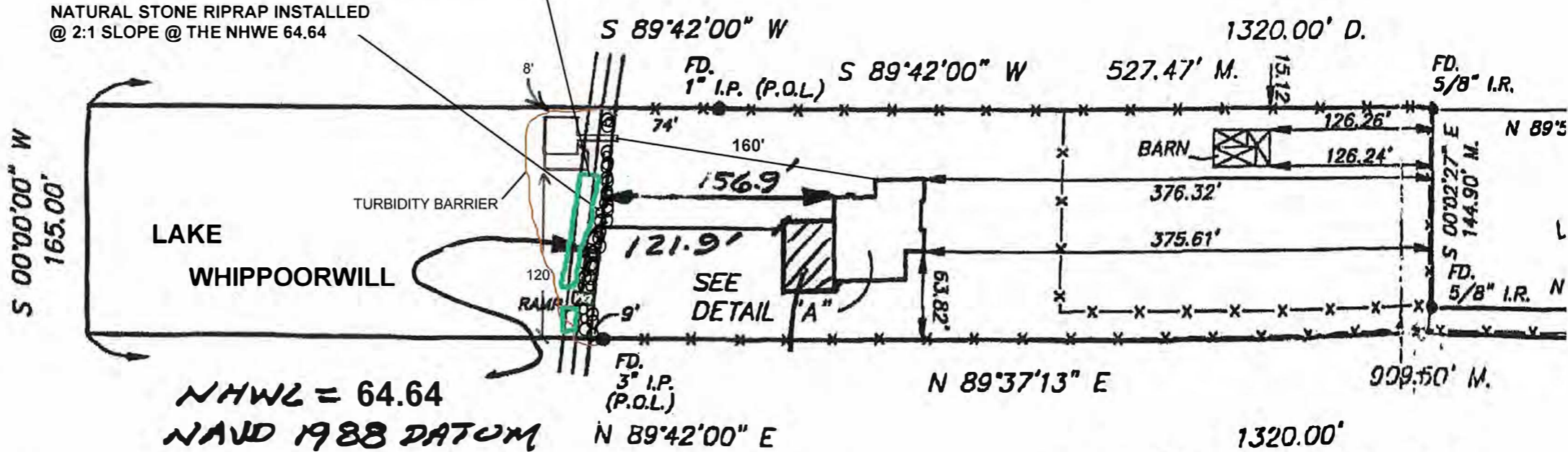

ENGINEER'S SEAL AS TO SITE PLAN ONLY

THIS IS TO CERTIFY THE LOCATION OF THE NHWL WAS LOCATED ON 10-6-2014 USING ORANGE COUNTY BENCH MARK C-1134031 NAVD 1988 DATUM TO DETERMINE THE NHWL IN RELATION TO THE EXISTING BUILDING AND PROPOSED RESIDENCE'S POOL



Darcy Unroe
 c=US, st=Florida,
 l=Orlando, o=Unroe
 Engineering, Inc., cn=Darcy
 Unroe,
 email=Darcy@unroeengine
 ering.com
 2022.03.24 13:05:20 -04'00'



received
3/24/2022

Unroe Engineering, Inc
Civil Engineering/Planning/Scientific Evaluations
PO Box 690942, Orlando, Florida 32869
Ph (407) 299-0650 <> Darcy@UnroeEngineering.com



Darcy Unroe
c=US, st=Florida,
l=Orlando,
o=Unroe
Engineering, Inc.,
cn=Darcy Unroe,
email=Darcy@unroe
engineering.com
2022.03.24
13:06:00 -04'00'

**3' X 150' NATURAL STONE >12" DIAMETER RIP-RAP
REVTMENT INSTALLED @ THE NHWE @ A 2:1 SLOPE**

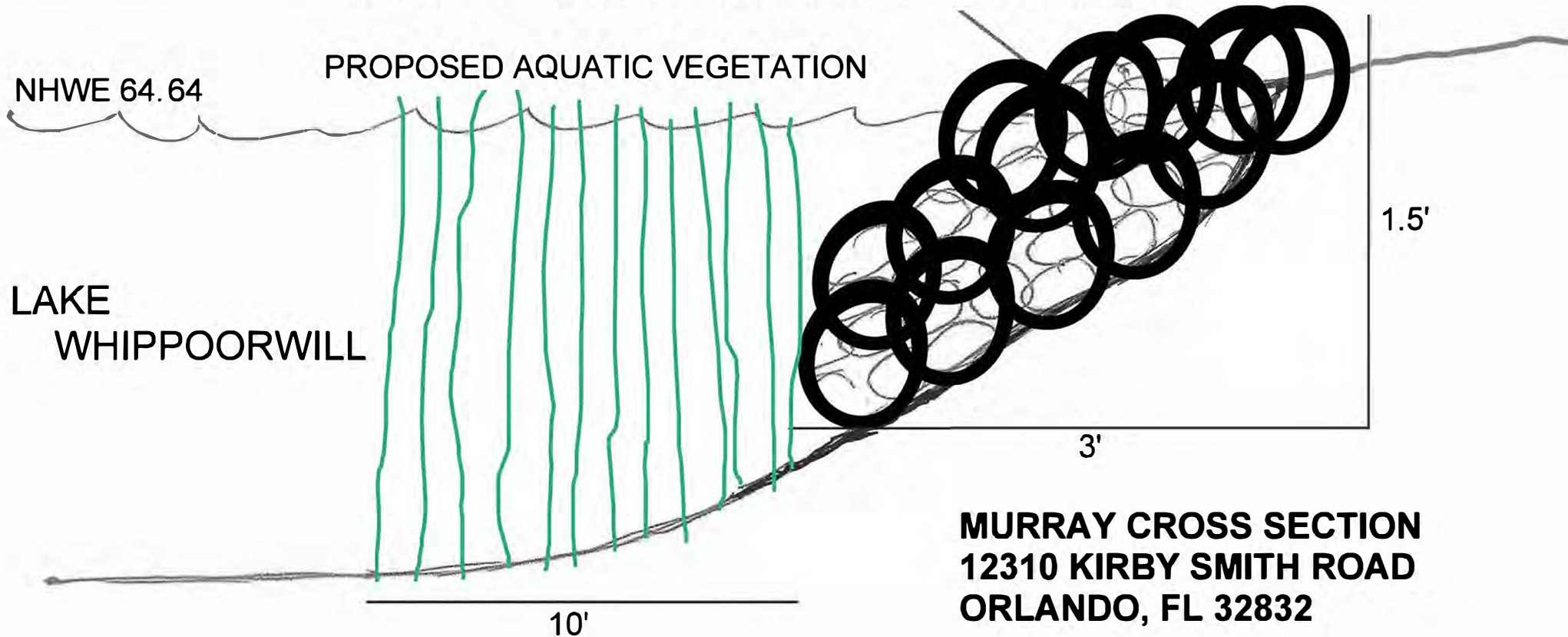

This item has been electronically signed and sealed by
Darcy Unroe, PE 60929 on the date indicated using a
Digital Signature
Printed copies of this document are not considered signed
and sealed and the signature must be verified on any
electronic copy.



